

Planetenrollermotor Serie MS



Bestellnr.	Typ	Code
080-040-01600	Planetenrollermotor 80,5ccm-W:Ø32	MS080C
080-040-01650	Planetenrollermotor 100ccm-W:Ø32	MS100C
080-040-01700	Planetenrollermotor 125,7ccm-W:Ø32	MS125C
080-040-01750	Planetenrollermotor 159,7ccm-W:Ø32	MS160C
080-040-01800	Planetenrollermotor 200ccm-W:Ø32	MS200C
080-040-01850	Planetenrollermotor 250ccm-W:Ø32	MS250C
080-040-01900	Planetenrollermotor 314,9ccm-W:Ø32	MS315C
080-040-01950	Planetenrollermotor 397ccm-W:Ø32	MS400C
080-040-02000	Planetenrollermotor 474,6ccm-W:Ø32	MS475C
080-040-02050	Planetenrollermotor 522,7ccm-W:Ø32	MS525C
080-040-02100	Planetenrollermotor 564,9ccm-W:Ø32	MS565C
080-040-02150	Planetenrollermotor 715ccm-W:Ø32	MS715C

HYDRAULIC MOTORS MS



APPLICATION

- » Conveyors
- » Metal working machine
- » Machines for agriculture
- » Road building machines
- » Mining machinery
- » Food industries
- » Special vehicles etc.

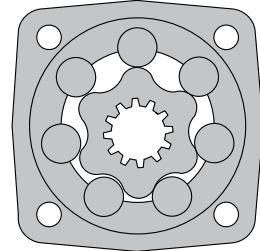

CONTENTS

Specification data	5÷6
Function diagrams	7÷12
Dimensions and mounting	13÷14
Wheel motor	15
Motor with Drum brake- MSB	16
Shaft extensions	17
Permissible shaft loads	18
Function diagram for MSB	18
Permissible Shaft Seal pressure.....	19
Tacho connection	19
Dimensions and mounting- MSS, V, U	20÷22
Internal Spline data	22
Order code	23

OPTIONS

- » Model- Disc valve, roll-gerotor
- » Flange and wheel mount
- » Short motor
- » Motor with Drum Brake
- » Tacho connection
- » Speed sensing
- » Side and rear ports
- » Shafts- straight, splined and tapered
- » Metric and BSPP ports
- » Other special features

GENERAL

Displacement, [cm ³ /rev.]	80,5÷564,9
Max. Speed, [RPM]	130÷810
Max. Torque, [daNm]	20÷58
Max. Output, [kW]	20÷6,9
Max. Pressure Drop, [bar]	100÷200
Max. Oil Flow, [l/min]	75
Min. Speed, [RPM]	5÷10
Permissible Shaft Loads, [daN]	P _a = 500
Pressure fluid	Mineral based- HLP(DIN 51524) or HM(ISO 6743/4)
Temperature range, [°C]	-30÷90
Optimal Viscosity range, [mm ² /s]	20÷75
Filtration	ISO code 20/16 (Min. recommended fluid filtration of 25 micron)

Oil flow in drain line

Pressure drop (bar)	Viscosity (mm ² /s)	Oil flow in drain line (l/min)
140	20	1,5
	35	1
210	20	3
	35	2

Pressure Losses

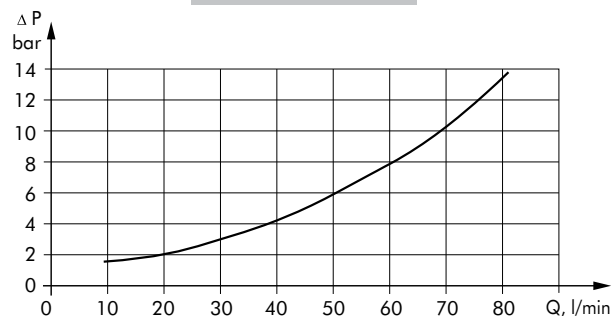

SPECIFICATION DATA

Type	MS 80	MS 100	MS 125	MS 160	MS 200	
Displacement [cm ³ /rev.]	80,5	100	125,7	159,7	200	
Max. Speed, [RPM]	cont.	810	750	600	470	375
	Int.*	1000	900	720	560	450
Max. Torque [daNm]	cont.	20	29,2	37,4	46	46
	Int.*	24	32	41	51,5	60
	peak**	26	32	41	51,5	65
Max. Output [kW]	cont.	16,4	19,5	20	15,5	14
	int.*	22	26	24	21,9	21
Max. Pressure Drop [bar]	cont.	175	205	205	205	160
	Int.*	210	225	225	225	210
	peak**	225	225	225	225	225
Max. Oil Flow [l/min]	cont.	65	75	75	75	75
	Int.*	80	90	90	90	90
Max. Inlet Pressure [bar]	cont.	210	210	210	210	210
	Int.*	250	250	250	250	250
	peak**	300	300	300	300	300
Max. Return Pressure with Drain Line [bar]	cont.	140	140	140	140	140
	Int.*	175	175	175	175	175
	peak**	210	210	210	210	210
Max. Starting Pressure with Unloaded Shaft, [bar]	12	10	10	8	8	
Min. Starting Torque [daNm]	at max. press. drop cont.	16,5	23,9	26	36,9	37,5
	at max. press. drop Int.*	19,4	26,4	31	40,5	48,5
Min. Speed***, [RPM]	10	10	8	8	6	
Weight, [kg] For Rear Ports + 0,4 kg	MS(F)	9,9	10,1	10,4	10,8	11,2
	MSW	10,4	10,6	10,9	11,3	11,7
	MSS	7,9	8,1	8,4	8,8	9,2
	MSV	5,8	6	6,3	6,7	7,1
	MSQ	10,3	10,5	10,8	11,2	11,6
	MSB	16,9	17,1	17,4	17,8	18,2

* Intermittent operation: the permissible values may occur for max. 10% of every minute.

** Peak load: the permissible values may occur for max. 1% of every minute.

*** For speeds of 5 RPM lower than given, consult factory or your regional manager.

- 1) Intermittent speed and intermittent pressure must not occur simultaneously.
- 2) Recommended filtration is per ISO cleanliness code 20/16. A nominal filtration of 25 micron or better.
- 3) Recommend using a premium quality, anti-wear type mineral based hydraulic oil HLP(DIN51524) or HM (ISO 6743/4).
If using synthetic fluids consult the factory for alternative seal materials.
- 4) Recommended minimum oil viscosity 13 mm²/s at operating temperatures.
- 5) Recommended maximum system operating temperature is 82°C.
- 6) To assure optimum motor life fill with fluid prior to loading and run at moderate load and speed for 10-15 minutes.

SPECIFICATION DATA (continued)

Type	MS 250	MS 315	MS 400	MS 475	MS 525	MS 565	
Displacement [cm ³ /rev.]	250	314,9	397	474,6	522,7	564,9	
Max. Speed, [RPM]	cont.	300	240	190	160	145	130
	Int.*	360	290	230	190	175	160
Max. Torque [daNm]	cont.	50	54	58	58	58	58
	Int.*	63	63	69	68	69	69
	peak**	72	84	85	84	85	85
Max. Output [kW]	cont.	13,5	11,5	10	8,4	7,6	6,9
	int.*	21	13,5	13	11,3	10,4	9,6
Max. Pressure Drop [bar]	cont.	140	120	100	85	80	75
	Int.*	175	140	120	100	90	85
	peak**	200	185	140	115	105	100
Max. Oil Flow [l/min]	cont.	75	75	75	75	75	75
	Int.*	90	90	90	90	90	90
Max. Inlet Pressure [bar]	cont.	210	210	210	210	210	210
	Int.*	250	250	250	250	250	250
	peak**	300	300	300	300	300	300
Max. Return Pressure with Drain Line [bar]	cont.	140	140	140	140	140	140
	Int.*	175	175	175	175	175	175
	peak**	210	210	210	210	210	210
Max. Starting Pressure with Unloaded Shaft, [bar]	8	8	8	8	8	8	
Min. Starting Torque [daNm]	at max. press. drop cont.	40	51	54	47	47	47
	at max. press. drop Int.*	50	65	63	55	55	55
Min. Speed***, [RPM]	6	5	5	5	5	5	
Weight, [kg] For Rear Ports +0,4 kg	MS(F)	11,7	12,4	13,3	14,4	14,6	15
	MSW	12,2	12,9	13,8	14,6	15,1	15,5
	MSS	9,7	10,4	11,3	12,1	12,6	13
	MSV	7,6	8,3	9,2	10	10,5	10,9
	MSQ	12,1	12,8	13,7	14,5	15,0	15,4
	MSB	18,7	19,4	20,3	21,1	21,6	23

* Intermittent operation: the permissible values may occur for max. 10% of every minute.

** Peak load: the permissible values may occur for max. 1% of every minute.

*** For speeds of 5 RPM lower than given, consult factory or your regional manager.

- 1) Intermittent speed and intermittent pressure must not occur simultaneously.
- 2) Recommended filtration is per ISO cleanliness code 20/16. A nominal filtration of 25 micron or better.
- 3) Recommend using a premium quality, anti-wear type mineral based hydraulic oil HLP(DIN51524) or HM (ISO 6743/4).
If using synthetic fluids consult the factory for alternative seal materials.
- 4) Recommended minimum oil viscosity 13 mm²/s at operating temperatures.
- 5) Recommended maximum system operating temperature is 82°C.
- 6) To assure optimum motor life fill with fluid prior to loading and run at moderate load and speed for 10-15 minutes.

FUNCTION DIAGRAMS

MS 80

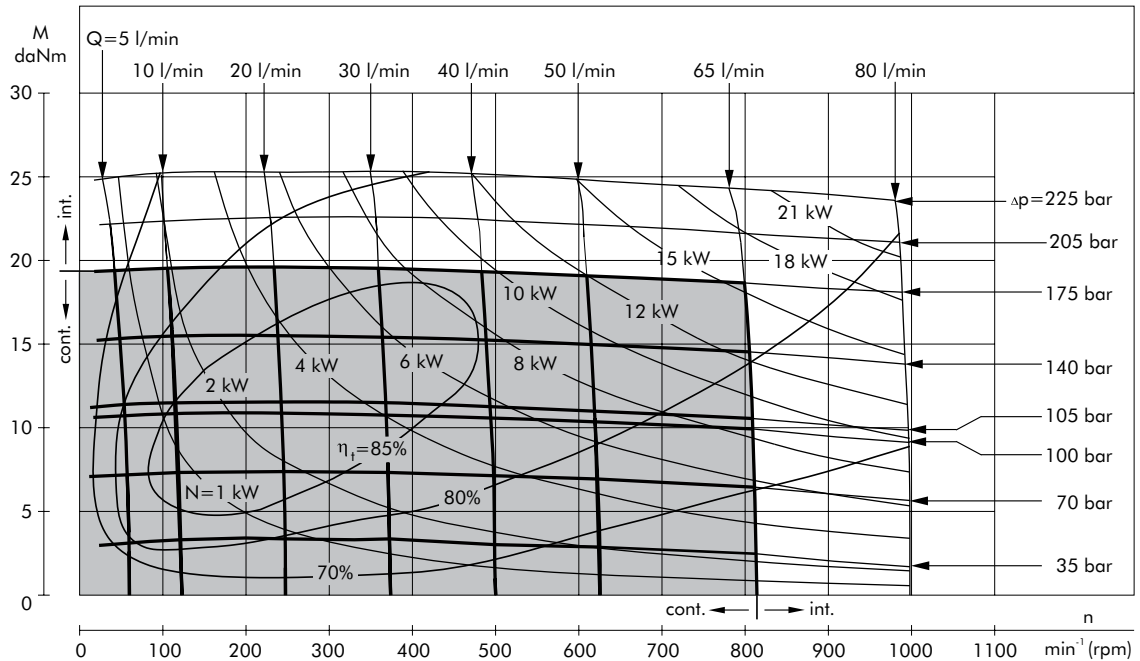

MS 100

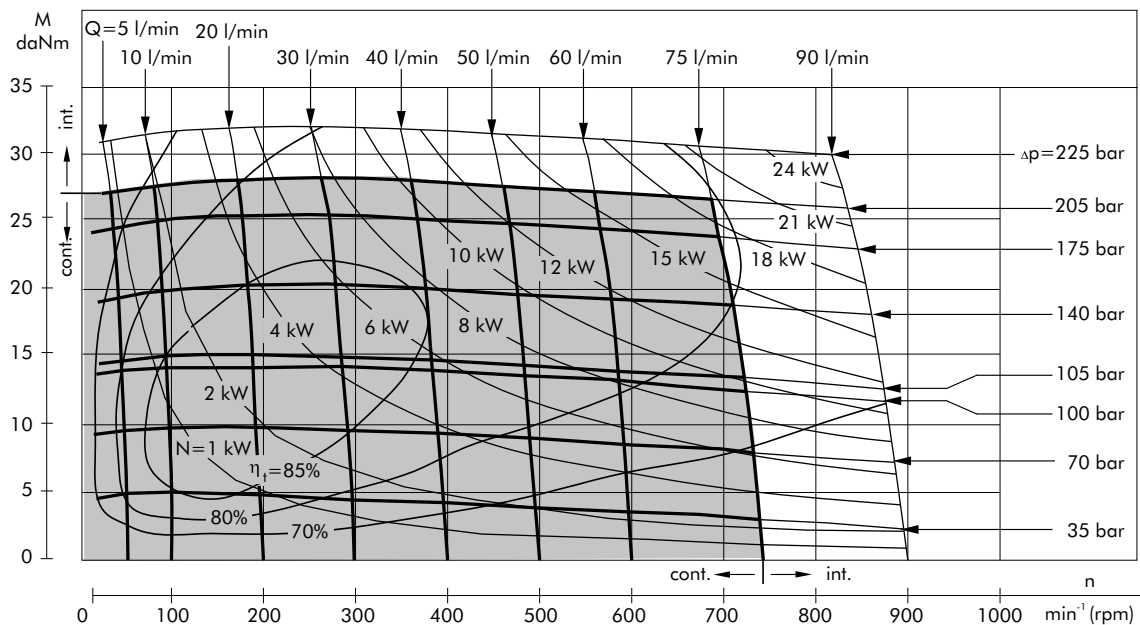

The function diagrams data was collected at back pressure 5 ÷ 10 bar and oil with viscosity of 32 mm²/s at 50° C.

FUNCTION DIAGRAMS

MS 125

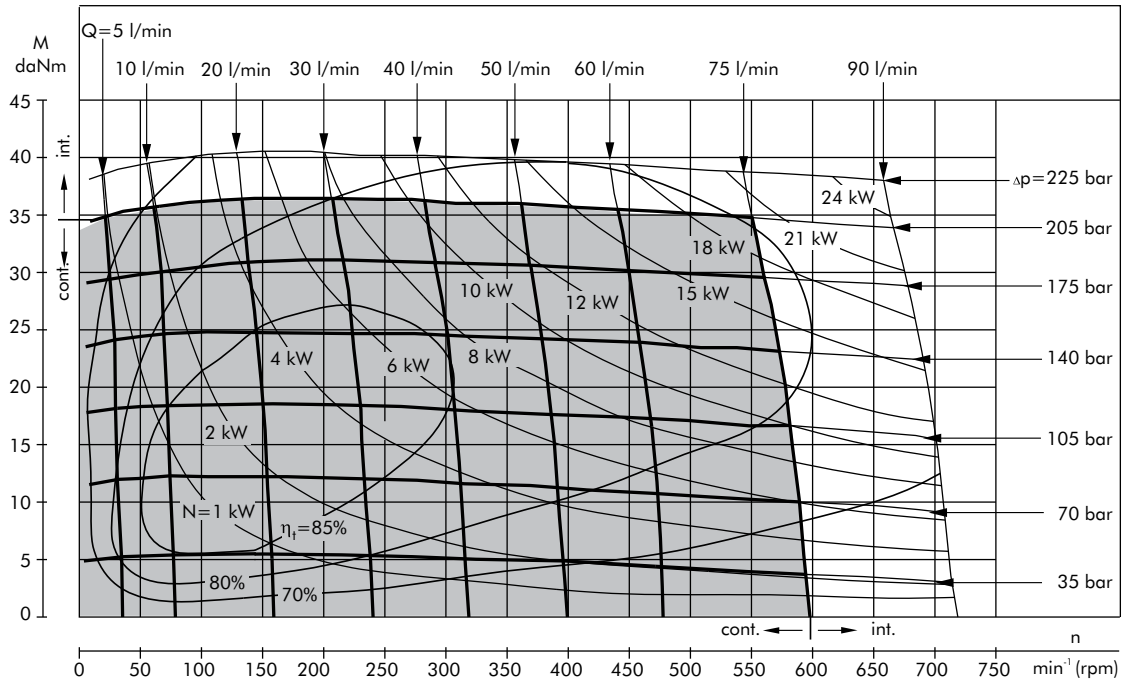

MS 160

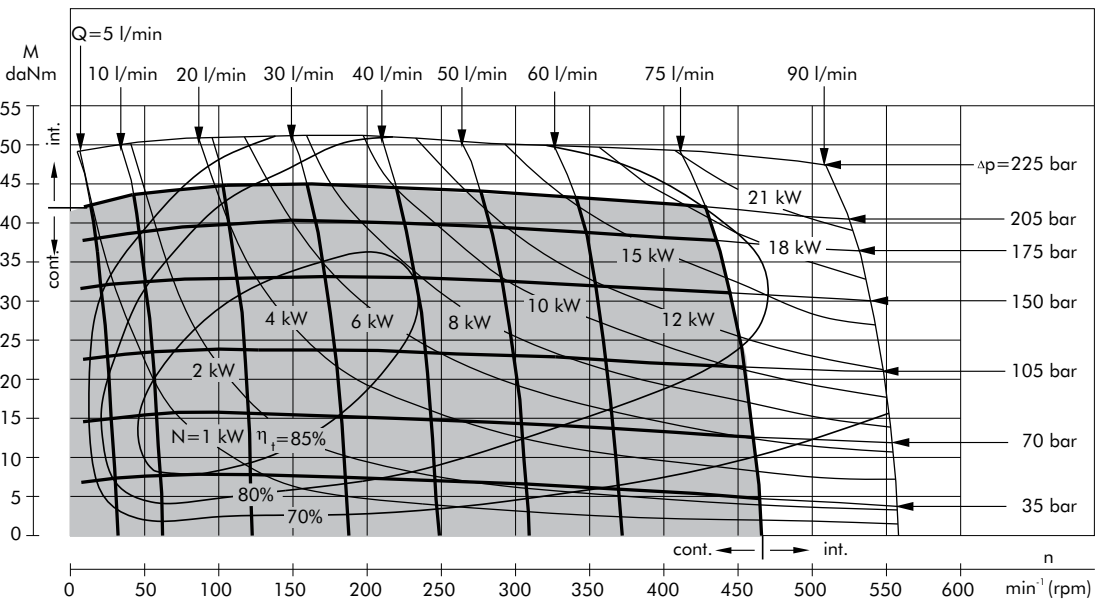

The function diagrams data was collected at back pressure 5 ÷ 10 bar and oil with viscosity of 32 mm²/s at 50° C.

FUNCTION DIAGRAMS

MS 200

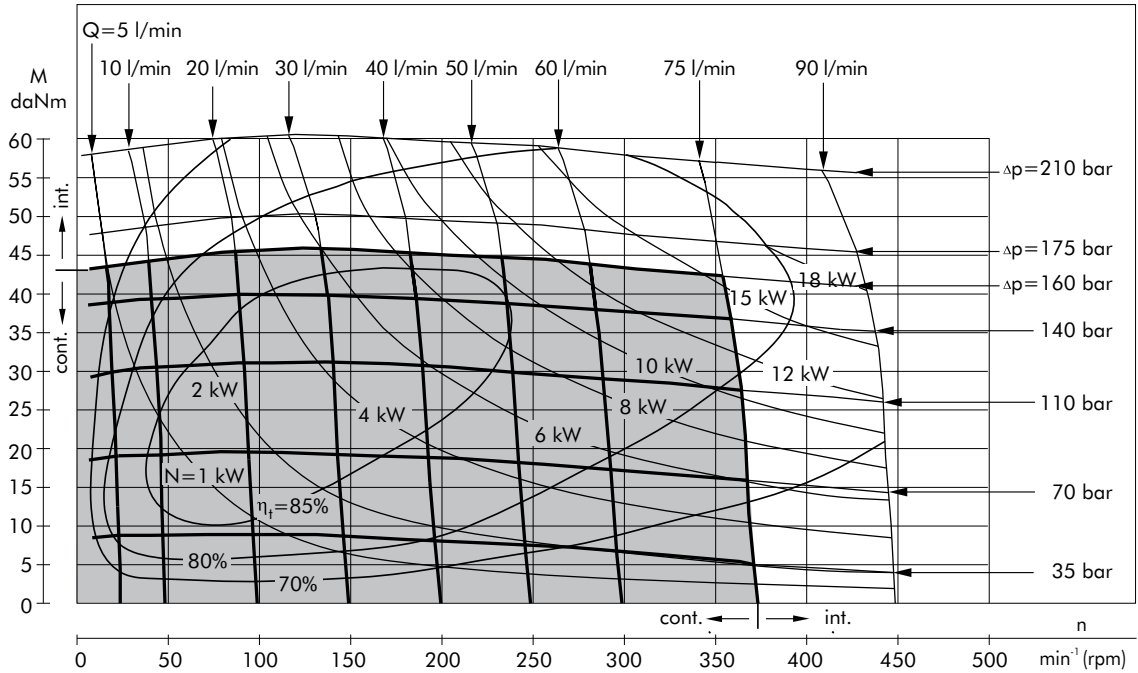

MS 250

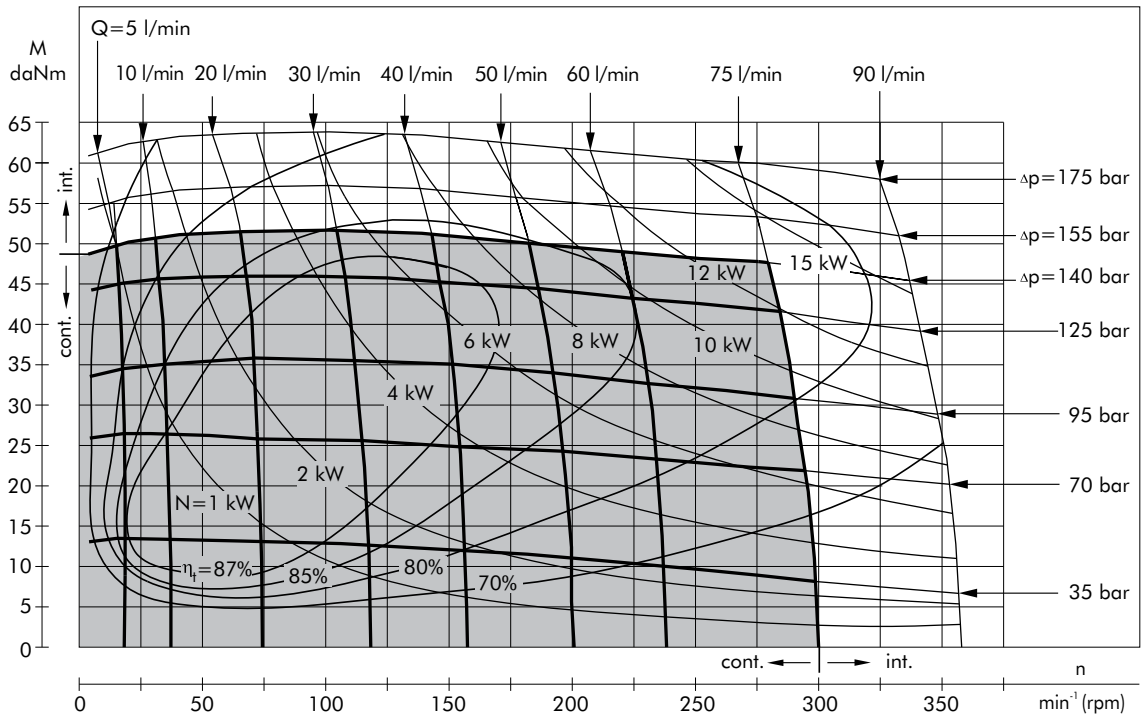

The function diagrams data was collected at back pressure $5 \div 10$ bar and oil with viscosity of $32 \text{ mm}^2/\text{s}$ at 50°C .

FUNCTION DIAGRAMS

MS 315

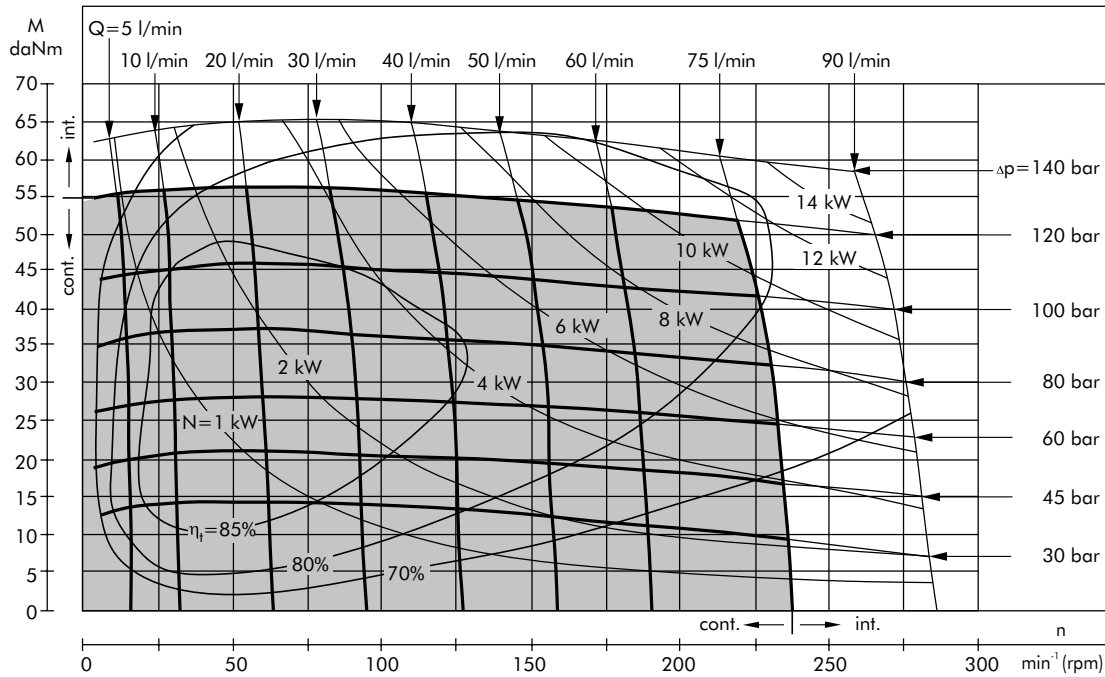

MS 400

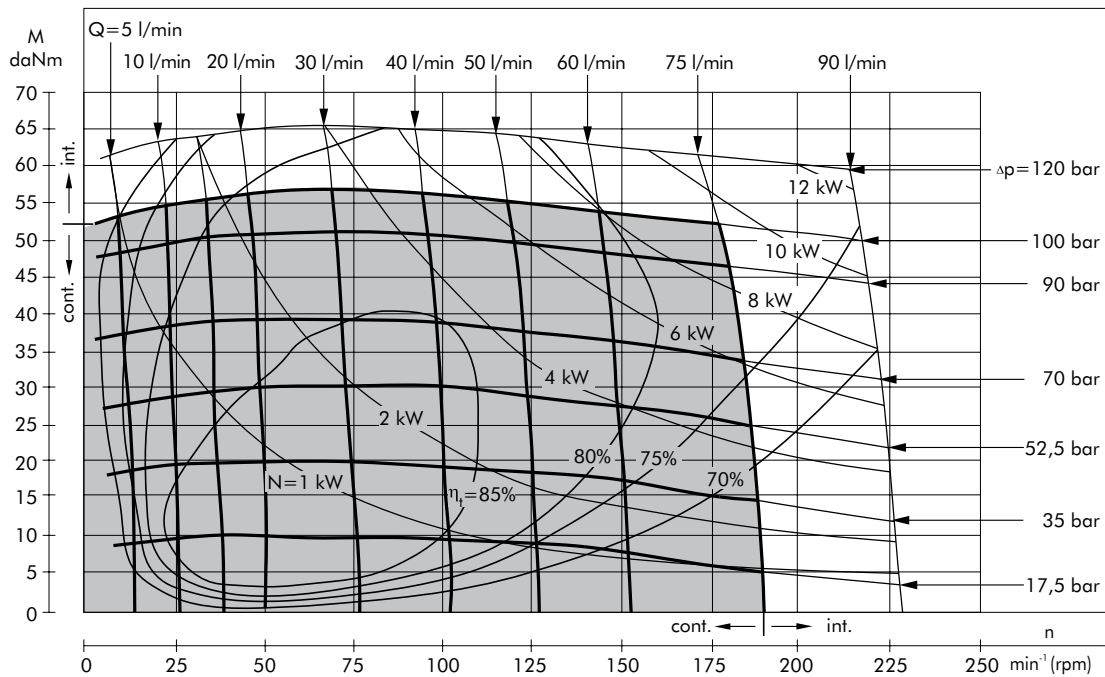

The function diagrams data was collected at back pressure 5 ÷ 10 bar and oil with viscosity of 32 mm²/s at 50° C.

FUNCTION DIAGRAMS

MS 475

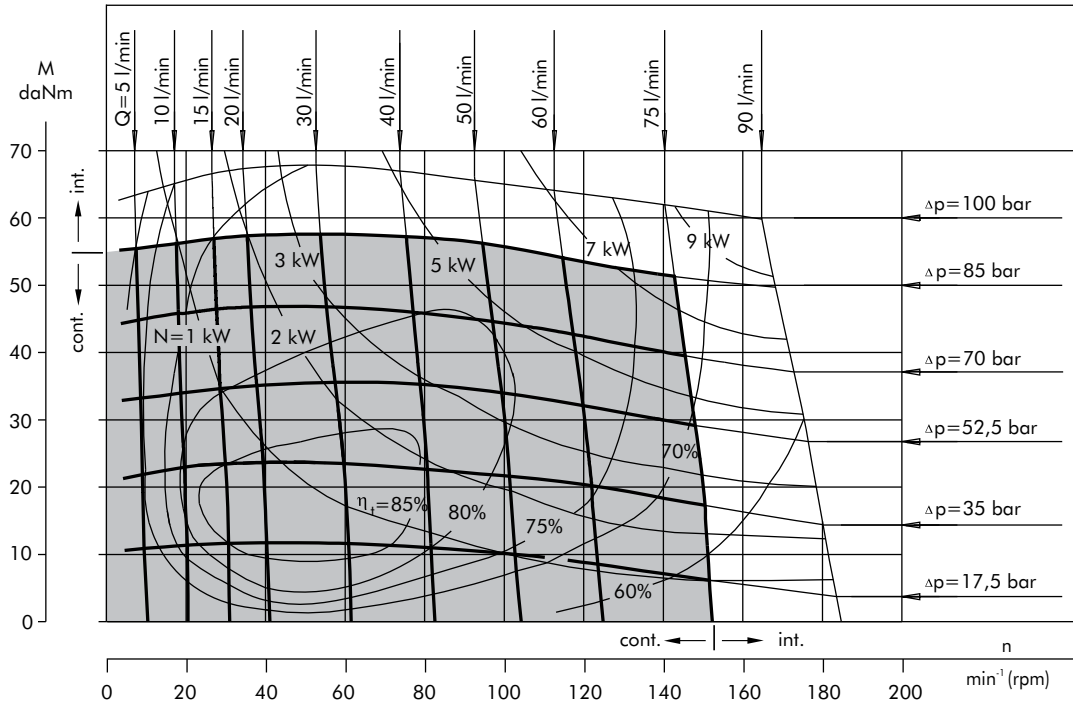

MS 525

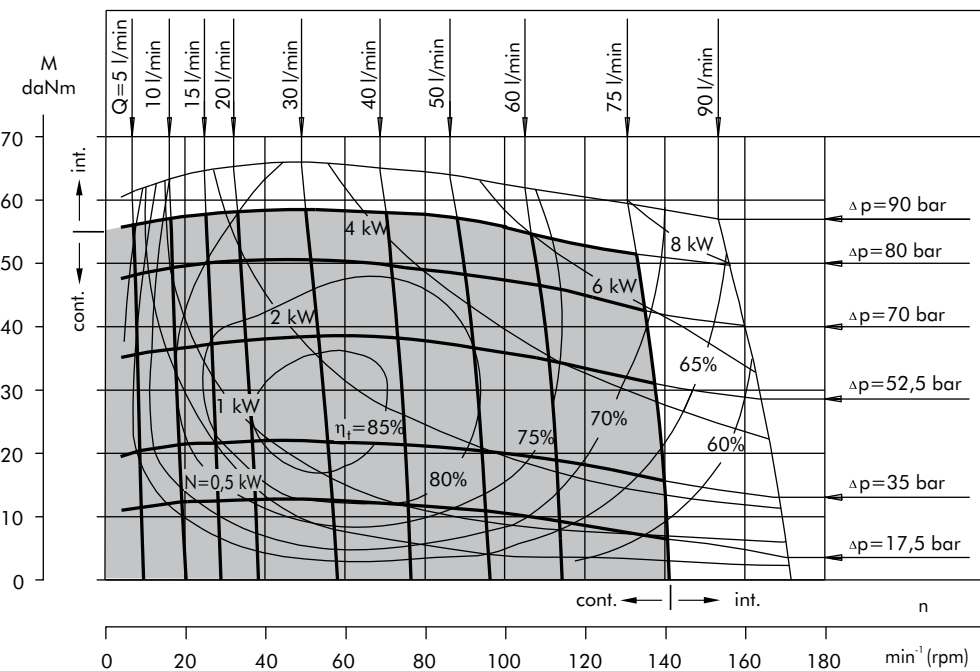

The function diagrams data was collected at back pressure $5 \div 10$ bar and oil with viscosity of $32 \text{ mm}^2/\text{s}$ at 50°C .

FUNCTION DIAGRAMS

MS 565

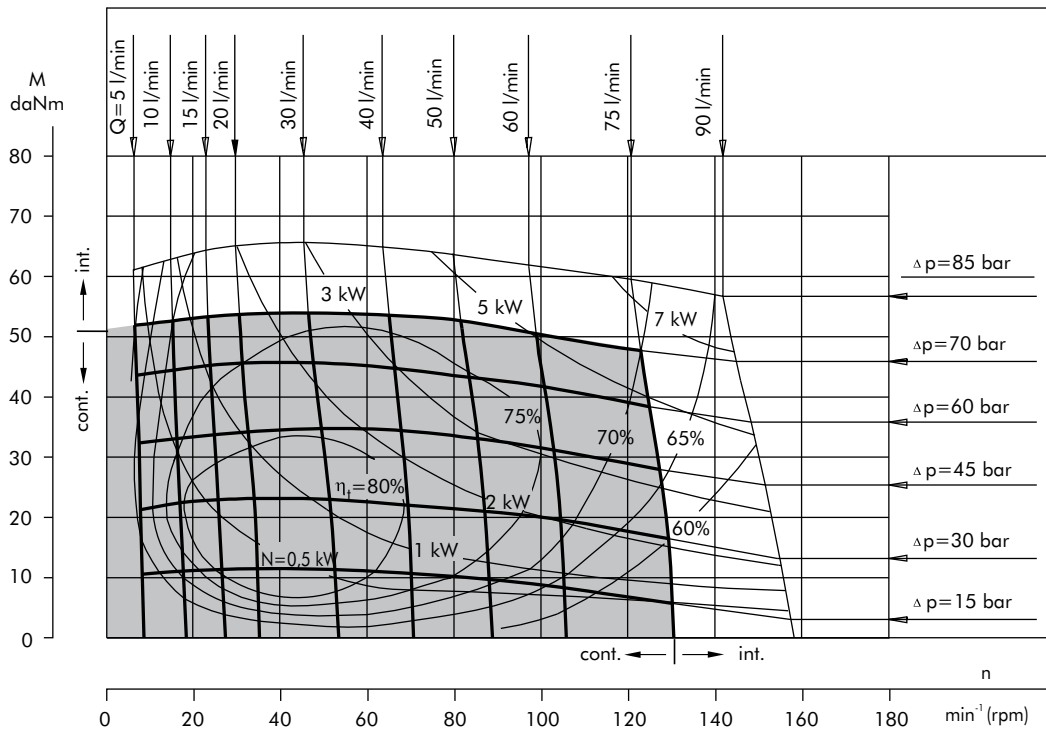

The function diagrams data was collected at back pressure $5 \div 10$ bar and oil with viscosity of $32 \text{ mm}^2/\text{s}$ at 50° C .

DIMENSIONS AND MOUNTING DATA

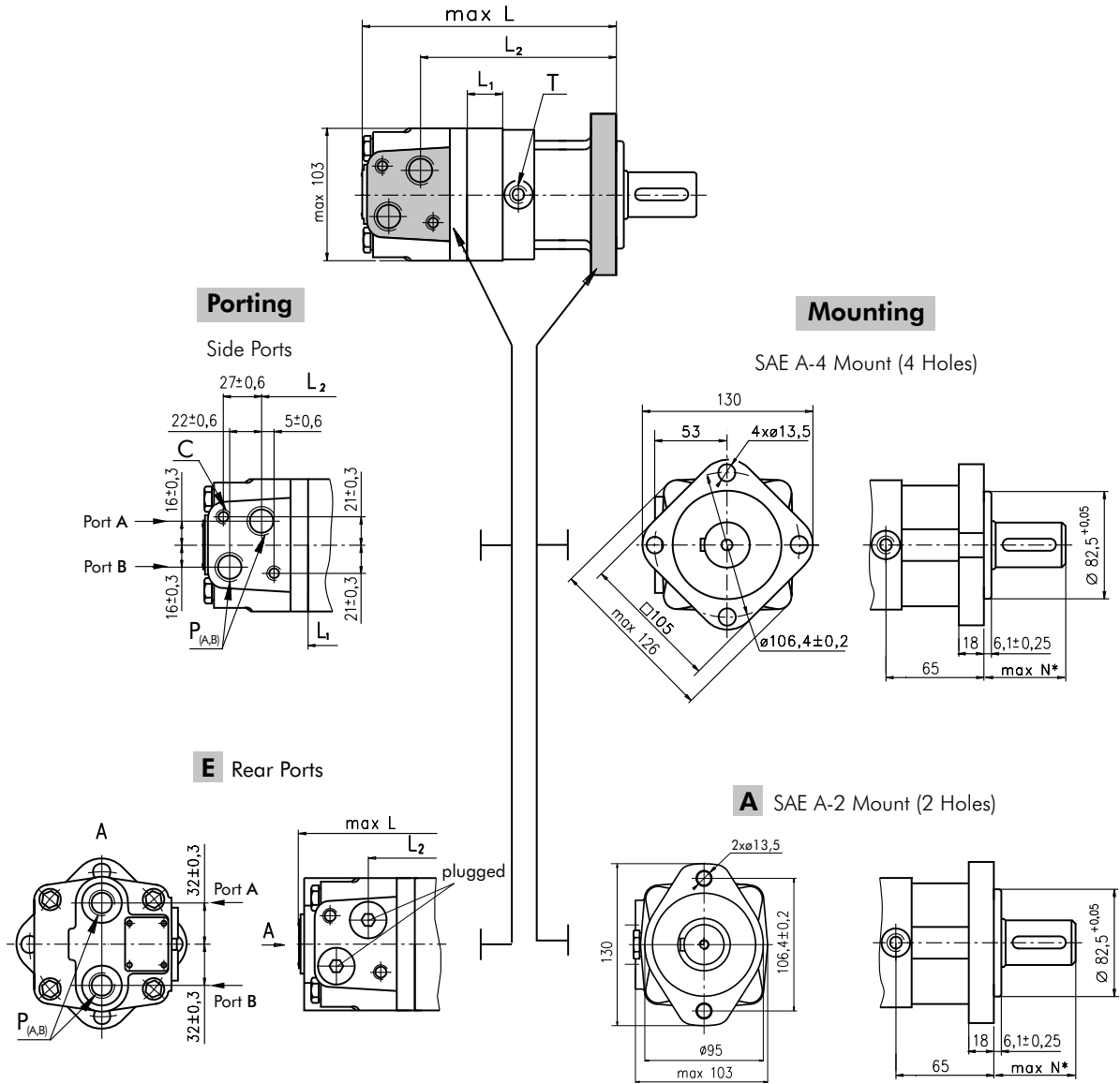

C: 2xM10-12 mm depth
P_(A,B): 2xG1/2 or 2xM22x1,5-15 mm depth
T: G ¼ or M14x1,5- 12 mm depth (plugged)

Standard Rotation
 Viewed from Shaft End
 Port A Pressurized - CW
 Port B Pressurized - CCW

Reverse Rotation
 Viewed from Shaft End
 Port A Pressurized - CCW
 Port B Pressurized - CW

*For N see page 17

Type	L ₁ , mm	L ₂ , mm	Type	L ₁ , mm	L ₂ , mm
MS(A) 80	168	124	MS(A)E 80	173	14
MS(A) 100	171	129	MS(A)E 100	177	17,4
MS(A) 125	176	132	MS(A)E 125	181	21,8
MS(A) 160	182	138	MS(A)E 160	187	27,8
MS(A) 200	189	145	MS(A)E 200	194	34,8
MS(A) 250	197	154	MS(A)E 250	203	43,5
MS(A) 315	209	165	MS(A)E 315	214	54,8
MS(A) 400	223	179	MS(A)E 400	228	69,4
MS(A) 475	237	193	MS(A)E 475	242	82,6
MS(A) 525	229	185	MS(A)E 525	234	74,5
MS(A) 565	235	191	MS(A)E 565	240	80,2

DIMENSIONS AND MOUNTING DATA

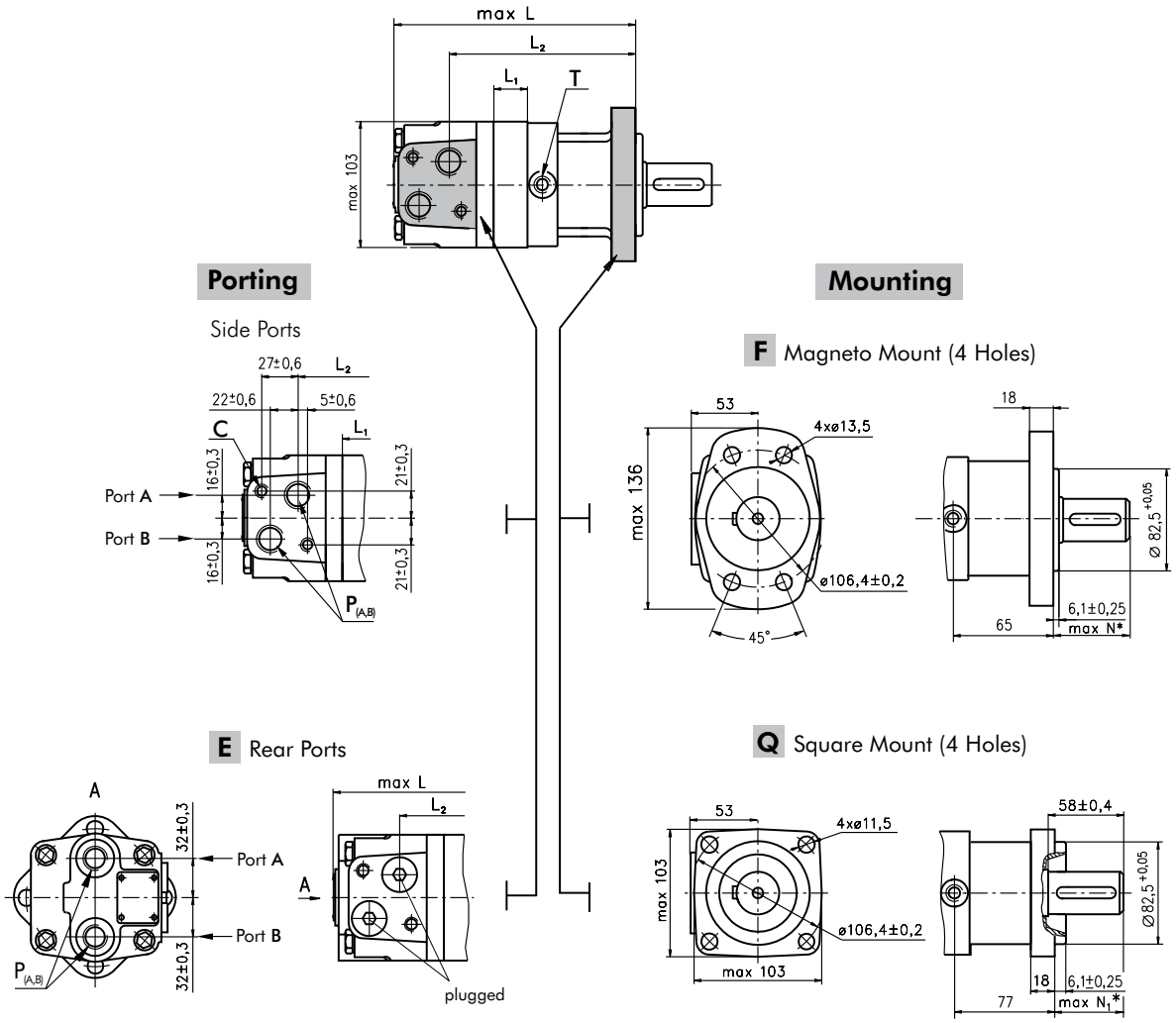

C: 2xM10-12 mm depth
P_(A,B): 2xG1/2 or 2xM22x1,5-15 mm depth
T: G ¼ or M14x1,5- 12 mm depth (plugged)

Standard Rotation
 Viewed from Shaft End
 Port A Pressurized - CW
 Port B Pressurized - CCW

Reverse Rotation
 Viewed from Shaft End
 Port A Pressurized - CCW
 Port B Pressurized - CW

*For N and N₁ see page 17

Type	L, mm	L ₂ , mm	Type	L, mm	L ₂ , mm	Type	L, mm	Type	L, mm	L ₁ , mm
MSF 80	168	124	MSQ 80	179	136	MSFE 80	173	MSQE 80	185	14
MSF 100	171	129	MSQ 100	183	140	MSFE 100	177	MSQE 100	189	17,4
MSF 125	176	132	MSQ 125	187	144	MSFE 125	181	MSQE 125	193	21,8
MSF 160	182	138	MSQ 160	193	150	MSFE 160	187	MSQE 160	199	27,8
MSF 200	189	145	MSQ 200	200	157	MSFE 200	194	MSQE 200	206	34,8
MSF 250	197	154	MSQ 250	209	166	MSFE 250	203	MSQE 250	215	43,5
MSF 315	209	165	MSQ 315	220	177	MSFE 315	214	MSQE 315	226	54,8
MSF 400	223	179	MSQ 400	235	192	MSFE 400	228	MSQE 400	241	69,4
MSF 475	237	193	MSQ 475	247	205	MSFE 475	242	MSQE 475	254	82,6
MSF 525	229	185	MSQ 525	240	197	MSFE 525	234	MSQE 525	246	74,5
MSF 565	235	191	MSQ 565	246	203	MSFE 565	240	MSQE 565	252	80,2

DIMENSIONS AND MOUNTING DATA -MSW

W Wheel Mount

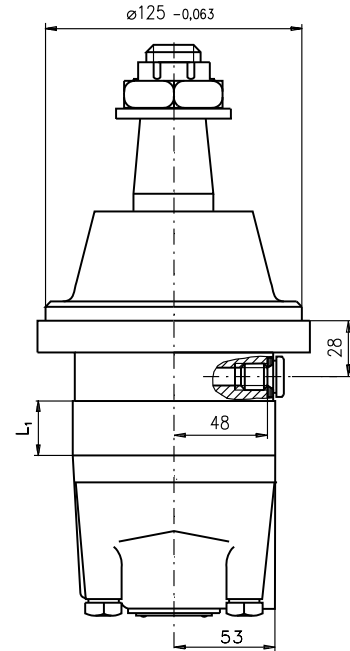
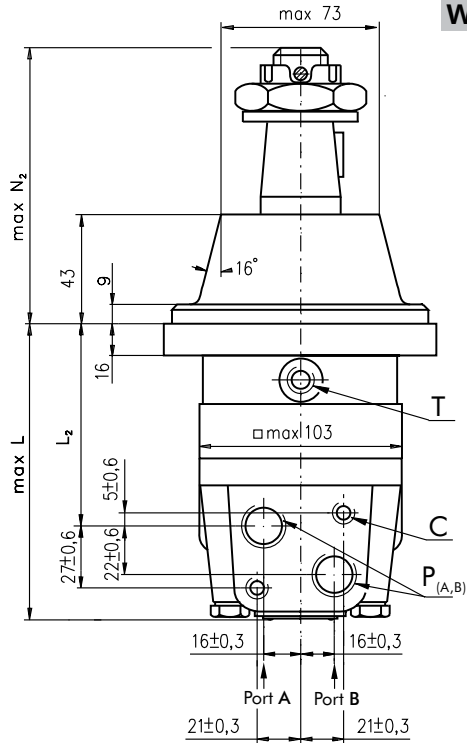

- C:** 2xM10-12 mm depth
- P_(A,B):** 2xG1/2 or 2xM22x1,5-15 mm depth
- T:** G 1/4 or M14x1,5 - 12 mm depth(plugged)

E Rear Port

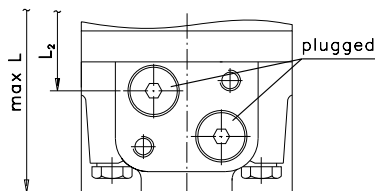
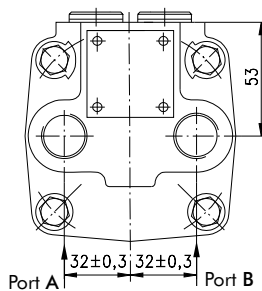

Standard Rotation
Viewed from Shaft End
Port A Pressurized - CW
Port B Pressurized - CCW

Reverse Rotation
Viewed from Shaft End
Port A Pressurized - CCW
Port B Pressurized - CW

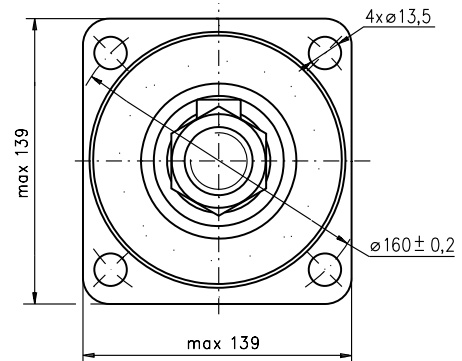

*For N₂ see page 17

Type	L ₁ , mm	L _{1r} , mm	L _{2r} , mm	Type	L ₁ , mm
MSW 80	129	14	87	MSWE 80	138
MSW100	133	17,4	91	MSWE 100	142
MSW 125	137	21,8	95	MSWE 125	146
MSW 160	143	27,8	101	MSWE 160	152
MSW 200	150	34,8	108	MSWE 200	159
MSW 250	159	43,5	117	MSWE 250	168
MSW 315	170	54,8	128	MSWE 315	179
MSW 400	184	69,4	143	MSWE 400	194
MSW 475	198	82,6	156	MSWE 475	207
MSW 525	190	74,5	148	MSWE 525	199
MSW 565	196	80,2	154	MSWE 565	205

DIMENSIONS AND MOUNTING DATA -MSB

B Motor with Drum Brake

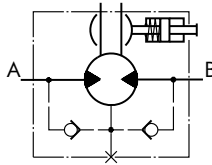

Actuating the brake level, the brake shaft is turned. The rectangular shape of the inner part of this shaft forces the brake pads to be pressed against the brake drum. This brakes the wheel or the winch drum.

Releasing the level, the springs pull it and the brake pads back to the initial position. The motor output shaft is released. Minimum angle adjustment is 10°. It can be adjusted by dismounting the level. Depending on the application You can choose the actuating direction of the brake level. The rod connection actuating the brake should be capable of moving at last 25 mm from neutral to extreme position.

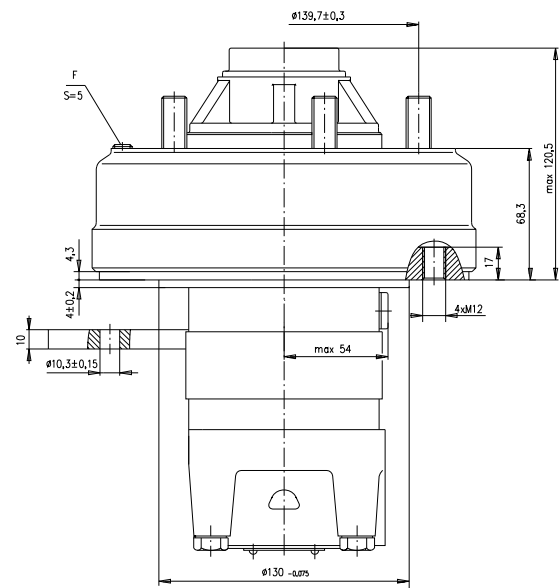
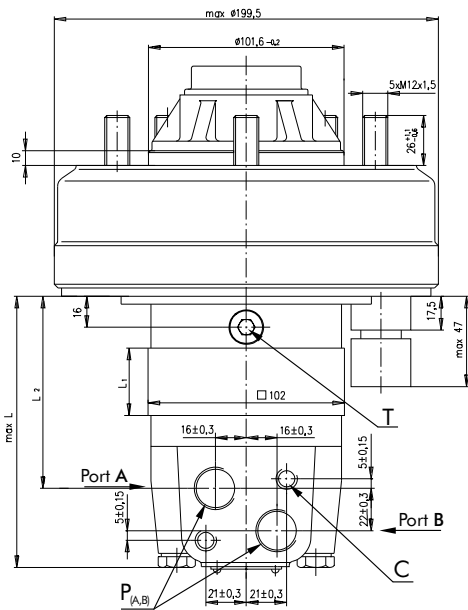
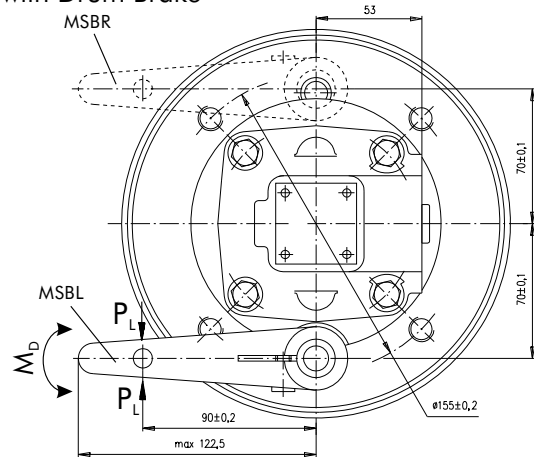

- C:** 2xM10-12 mm depth
- F:** Inspection hole for checking brake lining
- T:** G 1/4 or M14x1,5 - 12 mm depth (plugged)
- P_(A,B):** 2xG1/2 or 2xM22x1,5-15 mm depth

E Rear Port

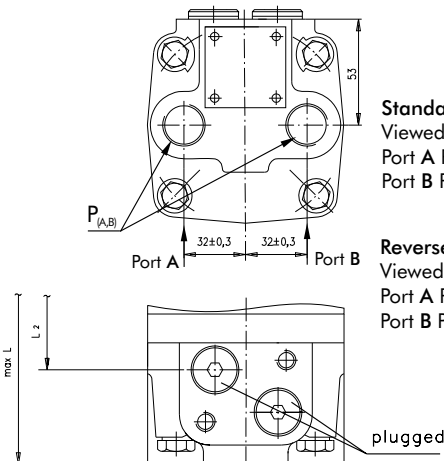

- Standard Rotation**
Viewed from Shaft End
Port A Pressurized - CW
Port B Pressurized - CCW
- Reverse Rotation**
Viewed from Shaft End
Port A Pressurized - CCW
Port B Pressurized - CW

Type	L, mm	L ₁ , mm	L ₂ , mm	Type	L, mm
MSB 80	119	14	74	MSBE 80	127
MSB 100	122	17,4	77	MSBE 100	130
MSB 125	126	21,8	82	MSBE 125	134
MSB 160	132	27,8	88	MSBE 160	140
MSB 200	139	34,8	95	MSBE 200	147
MSB 250	148	43,5	110	MSBE 250	156
MSB 315	159	54,8	115	MSBE 315	167
MSB 400	174	69,4	130	MSBE 400	182
MSB 475	188	82,6	143	MSBE 475	196
MSB 525	180	74,5	135	MSBE 525	188
MSB 565	186	80,2	141	MSBE 565	192

SHAFT EXTENSIONS

C - $\varnothing 32$ straight, Parallel key A10x8x45 DIN 6885
Max. Torque 77 daNm

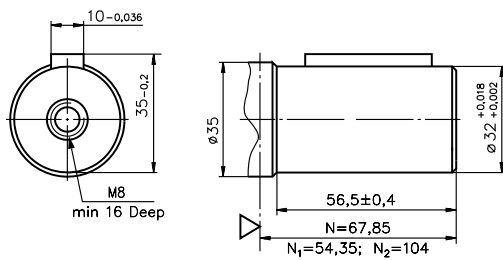

K - tapered 1:10, Parallel key B6x6x20 DIN 6885
Max. Torque 95 daNm

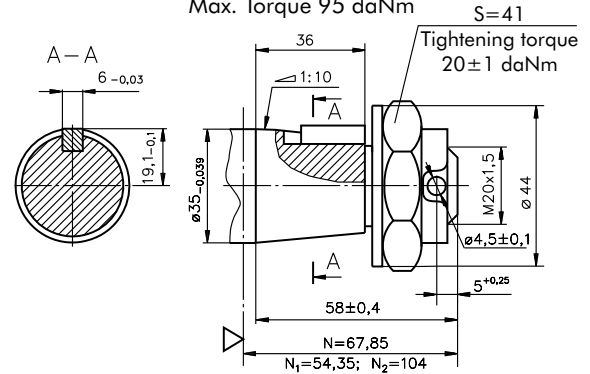

CO - $\varnothing 1\frac{1}{4}$ " straight, Parallel key $\frac{5}{16}$ "x $\frac{5}{16}$ "x $1\frac{1}{4}$ "BS46
Max. Torque 77 daNm

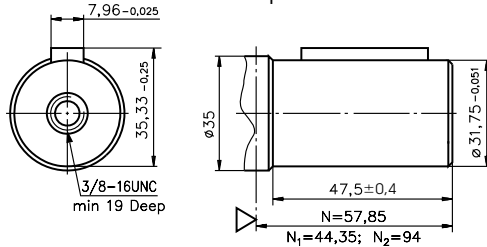

SH - $\varnothing 1\frac{1}{4}$ " splined 14T, DP12/24 ANSI B92.1-1976
Max. Torque 95 daNm

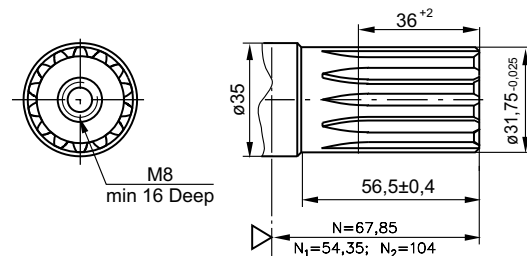

SL - $\varnothing 34,85$ p.t.o. DIN 9611 Form 1
Max. Torque 77 daNm

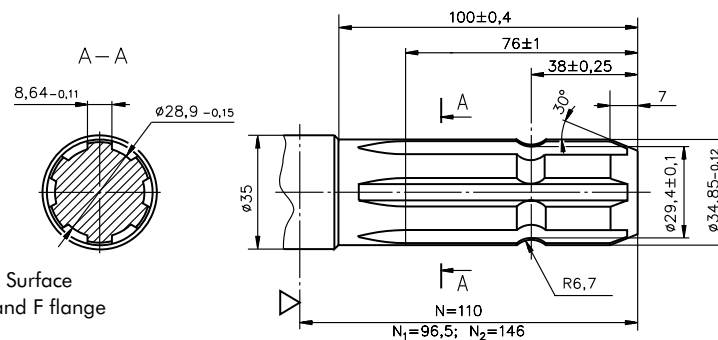

▽ - Motor Mounting Surface
N - for standart, A and F flange
N₁ - for Q flange
N₂ - for W flange

PERMISSIBLE SHAFT LOADS

The output shaft runs in tapered bearings that permit high axial and radial forces. Curve "1" shows max. radial shaft load. Any shaft load exceeding the values quoted in the curve will seriously reduce motor life. The two other curves apply to a B10 bearing life of 3000 hours at 200 RPM.

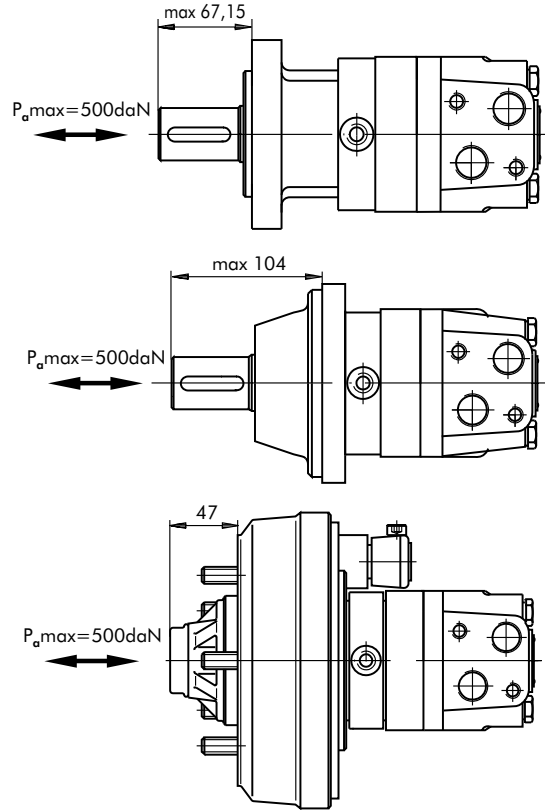
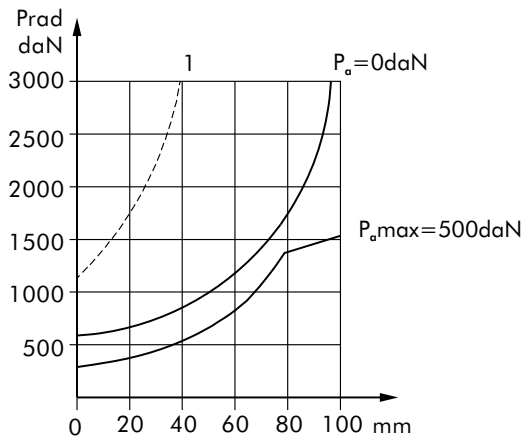

FUNCTION DIAGRAM MSB

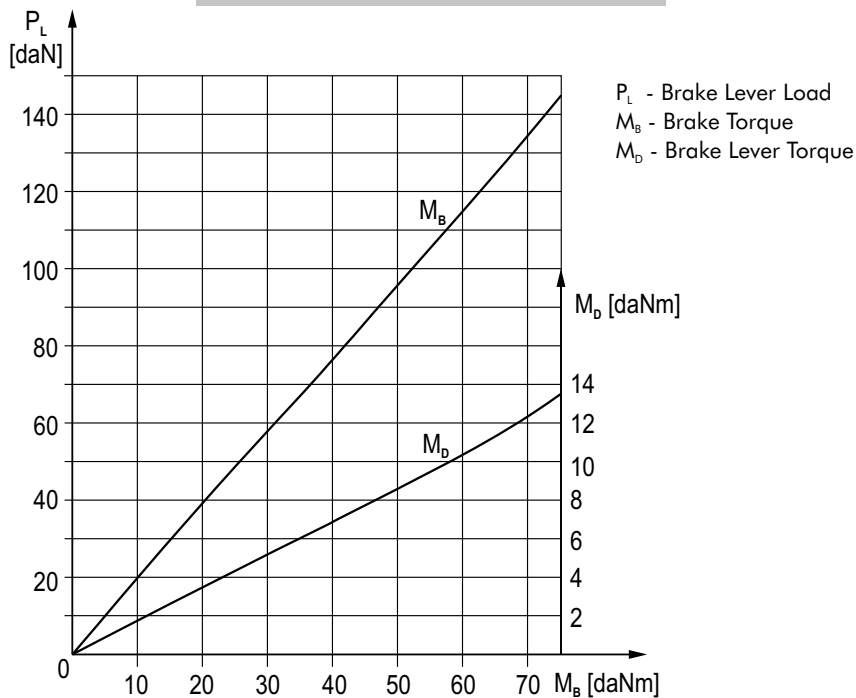

MAX. PERMISSIBLE SHAFT SEAL PRESSURE

Max. return pressure without drain line or
max. pressure in the drain line

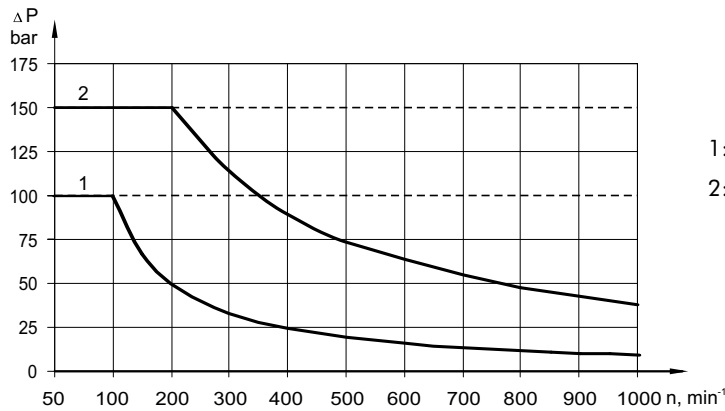

1: Drawing for Standard Shaft Seal
2: Drawing for High Pressure Seal ("U" Seal)

— - continuous operations
- - - - - intermittent operations

MOTORS WITH TACHO CONNECTION

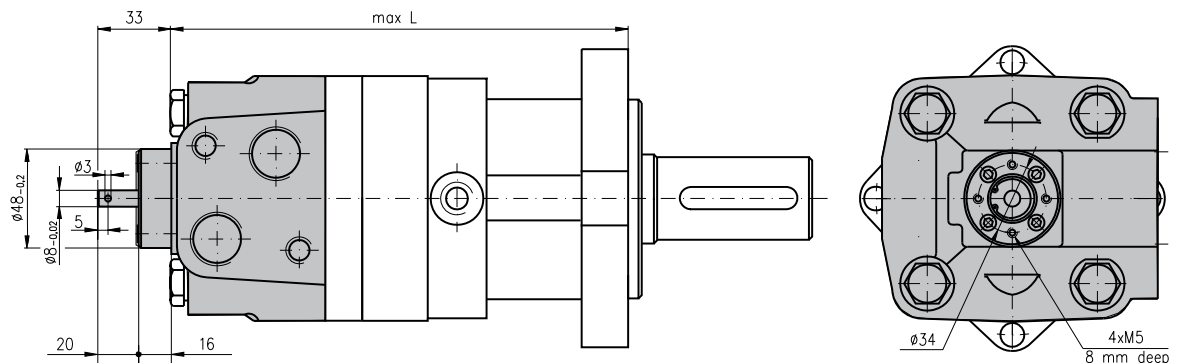

DIMENSIONS AND MOUNTING DATA - MSS, MSV and MSU

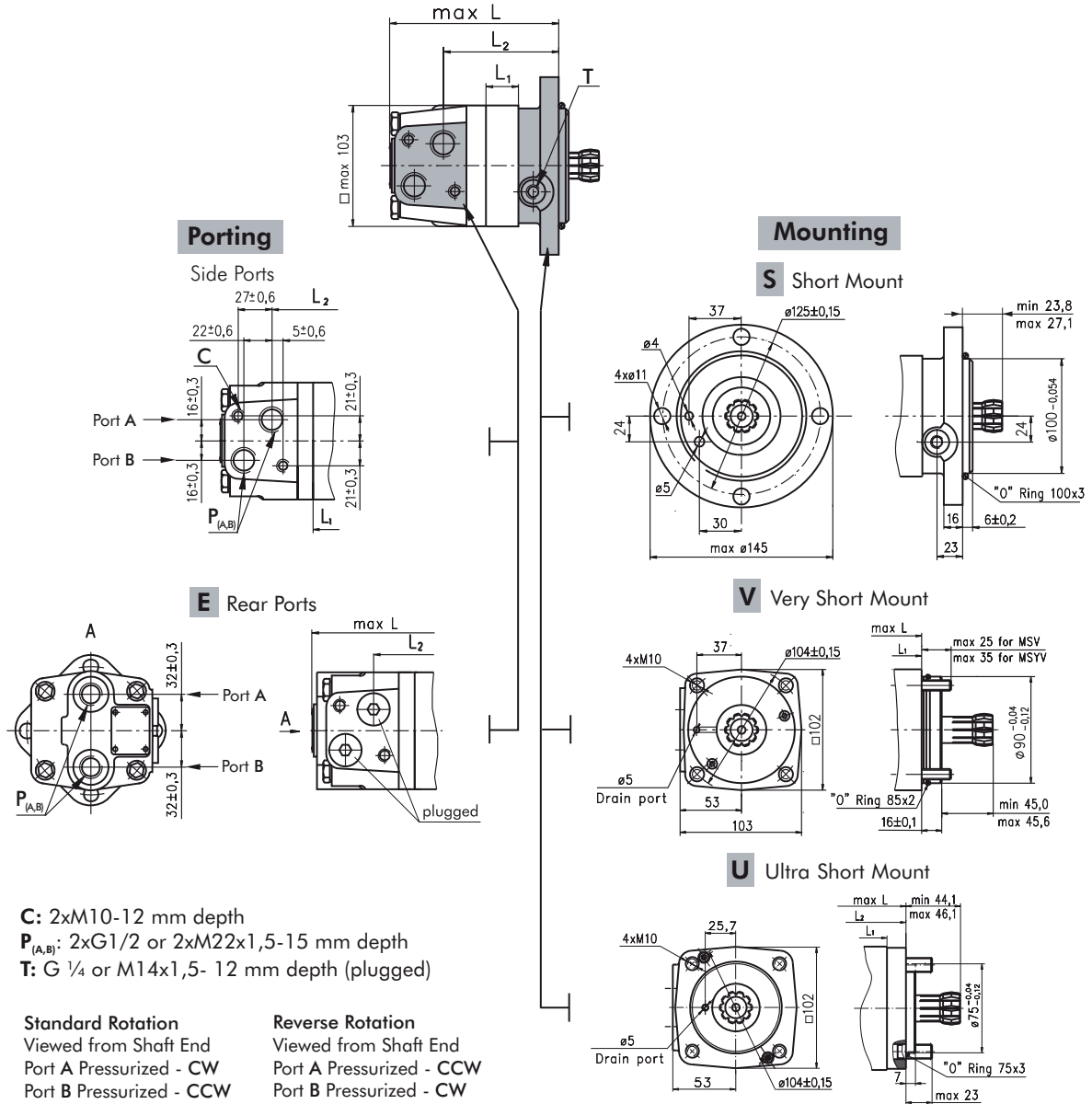

Type	L ₁ , mm	L ₂ , mm	Type	L ₁ , mm	Type	L ₁ , mm	L ₂ , mm	Type	L ₁ , mm	Type	L ₁ , mm	L ₂ , mm	Type	L ₁ , mm	L ₂ , mm
MSS 80	125	83	MSSE 80	134	MSV 80	91	52	MSVE 80	97	MSU 80	105,5	63	MSUE 80	111,5	14
MSS 100	129	87	MSSE 100	138	MSV 100	94	55,5	MSVE 100	100	MSU 100	109	66,5	MSUE 100	115	17,4
MSS 125	133	90	MSSE 125	141	MSV 125	100	60	MSVE 125	105	MSU 125	113	71	MSUE 125	119	21,8
MSS 160	139	96	MSSE 160	147	MSV 160	106	66	MSVE 160	111	MSU 160	119	77	MSUE 160	125	27,8
MSS 200	146	103	MSSE 200	154	MSV 200	113	73	MSVE 200	118	MSU 200	126	84	MSUE 200	132	34,8
MSS 250	155	112	MSSE 250	163	MSV 250	121	81,5	MSVE 250	126	MSU 250	135	92,5	MSUE 250	141	43,5
MSS 315	166	123	MSSE 315	174	MSV 315	133	93	MSVE 315	138	MSU 315	146	104	MSUE 315	152	54,8
MSS 400	181	138	MSSE 400	189	MSV 400	147	108	MSVE 400	153	MSU 400	160	119	MSUE 400	167	69,4
MSS 475	194	152	MSSE 475	203	MSV 475	161	121	MSVE 475	166	MSU 475	174	132	MSUE 475	180	82,6
MSS 525	186	144	MSSE 525	195	MSV 525	153	113	MSVE 525	158	MSU 525	166	124	MSUE 525	172	74,5
MSS 565	192	150	MSSE 565	201	MSV 565	159	119	MSVE 565	164	MSU 565	172	130	MSUE 565	178	80,2

DIMENSIONS OF THE ATTACHED COMPONENT

For MSS

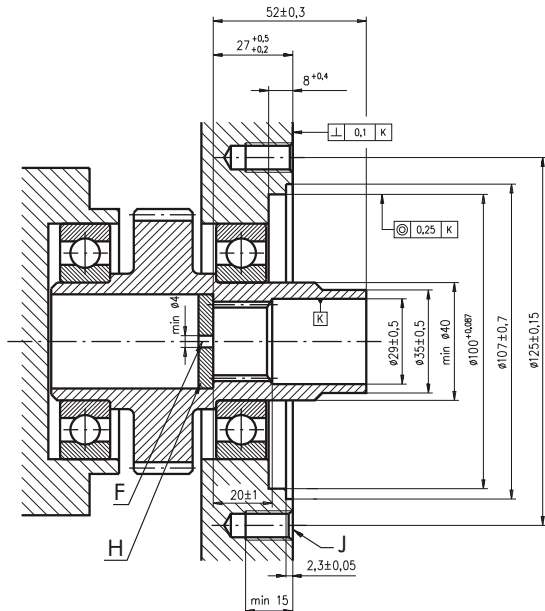

- F:** Oil circulation hole
- H:** Hardened stop plate
- J:** 4xM10-16 mm depth, 90°

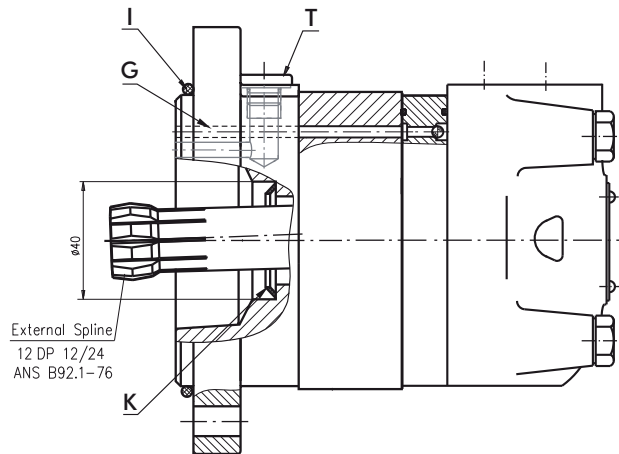

- G:** Internal drain channel
- I:** O- Ring 100x3mm
- K:** Conical seal ring
- T:** Drain connection G1/4 or M14x1,5

For MSV

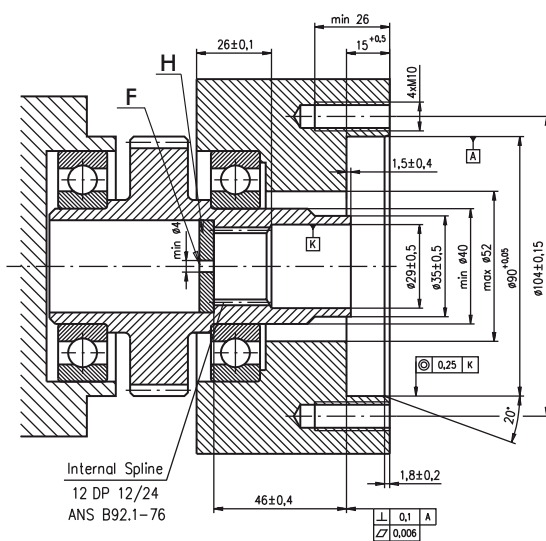

Internal Spline
12 DP 12/24
ANS B92.1-76

- F:** Oil circulation hole
- H:** Hardened stop plate

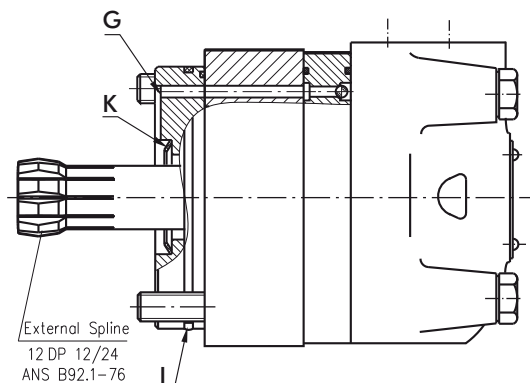

- G:** Internal drain channel
- I:** O- Ring 85x2 mm
- K:** Conical seal ring

DIMENSIONS OF THE ATTACHED COMPONENT(continued)

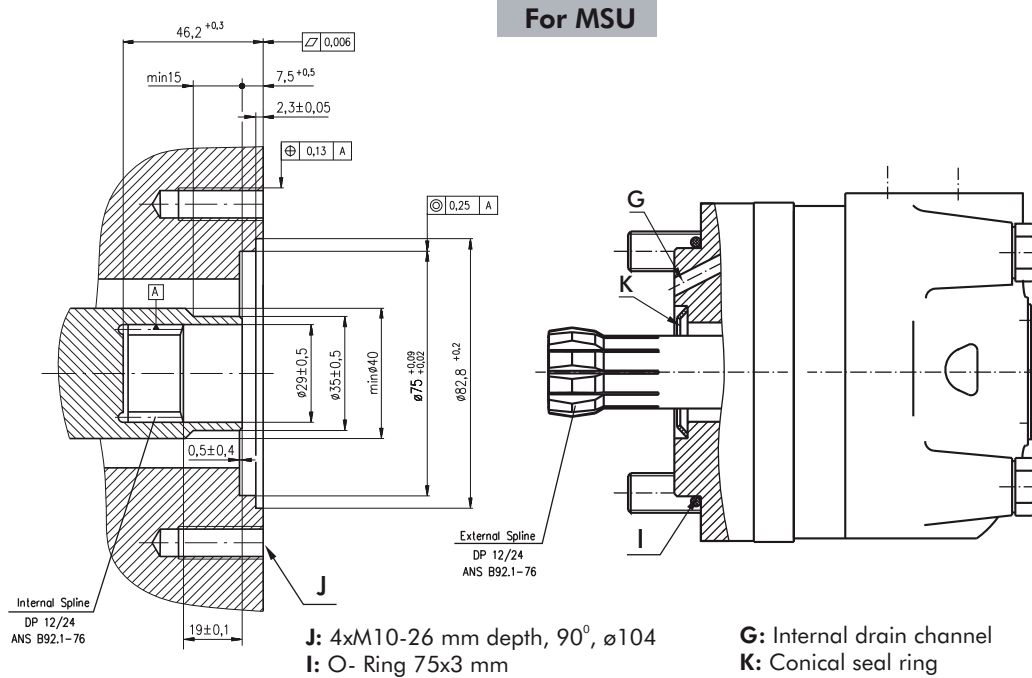

DRAIN CONNECTION

A drain line ought to be used when pressure in the return line can exceed the permissible pressure. It can be connected:

- For MSS at the drain port of the motor;
- For MSV and MSU at the drain connection of the attached component. The maximum pressure in the drain line is limited by the attached component and its shaft seal.

The drain line must be possible for oil to flow freely between motor and attached component and must be led to the tank. The maximum pressure in the drain line is limited by the attached component and its seal.

INTERNAL SPLINE DATA FOR THE ATTACHED COMPONENT

Standard ANS B92.1-1976, class 5
[m=2.1166; corrected x.m=+0,8]

Fillet Root Side Fit		mm
Number of Teeth	z	12
Diametral Pitch	DP	12/24
Pressure Angle		30°
Pitch Dia.	D	25,4
Major Dia.	D _{ri}	28,0 _{-0,1}
Minor Dia.	D _i	23,0 ^{+0,033}
Space Width [Circular]	L _o	4,308±0,020
Fillet Radius	R	0,2
Max. Measurement between Pin	L	17,62 ^{+0,15}
Pin Dia.	d	4,835±0,001

Above are when hardened

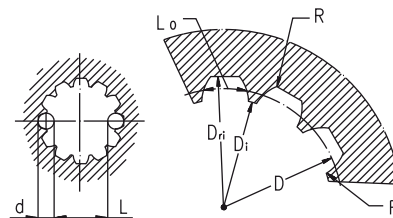

Hardening Specification:
HV=750±50 on the surface
HV=560 at 0,7±0,2 mm case depth
Material 20 MoCr4 EN 10084 or better

ORDER CODE

	1	2	3	4	5	6	7	8	9
MS									

Pos.1 - Mounting Flange

- omit - SAE A-4 mount, four holes
- A** - SAE A-2 mount, two holes
- F** - Magneto mount, four holes
- Q** - Square mount, four holes
- B** - Motor with drum brake
- S** - Short mount
- V** - Very short mount
- U** - Ultra short mount
- W** - Wheel mount

Pos.2 - Port type

- omit - Side ports
- E** - Rear ports

Pos.3 - Displacement code

- 80** - 80,5 [cm³/rev]
- 100** - 100,0 [cm³/rev]
- 125** - 125,7 [cm³/rev]
- 160** - 159,7 [cm³/rev]
- 200** - 200,0 [cm³/rev]
- 250** - 250,0 [cm³/rev]
- 315** - 314,9 [cm³/rev]
- 400** - 397,0 [cm³/rev]
- 475** - 474,6 [cm³/rev]
- 525** - 522,7 [cm³/rev]
- 565** - 564,9 [cm³/rev]

Pos.4 - Shaft Extensions*

- omit - for **B**, **S**, **U** and **V** mounting flange
- C** - $\varnothing 32$ straight, Parallel key A10x8x45 DIN6885
- CO** - $\varnothing 1 \frac{1}{4}$ " straight, Parallel key $\frac{5}{16}$ "x $\frac{5}{16}$ "x1 $\frac{1}{4}$ " BS46
- K** - $\varnothing 35$ tapered 1:10, Parallel key B6x6x20 DIN6885
- SL** - $\varnothing 34,85$ p.t.o. DIN 9611 Form 1
- SH** - $\varnothing 1 \frac{1}{4}$ " splined 14T ANSI B92.1-1976

Pos. 5 - Shaft Seal Version (see page 19)

- omit - Low pressure seal
- U** - High pressure seal

Pos. 6 - Ports

- omit - BSPP (ISO 228)
- M** - Metric (ISO 262)

Pos. 7 - Actuating Direction**

- /R** - Right
- /L** - Left

Pos. 8 - Special Features (see page 65)

Pos. 9 - Design Series

- omit - Factory specified

NOTES:

- * The permissible output torque for shafts must not be exceeded!
- ** Only for MSB

The hydraulic motors are manganese-phosphatized as standard.