

Planetenrollermotor Serie MT



Bestellnr.	Typ	Code
080-050-02200	Planetenrollermotor 161,1ccm-W:Ø40	MT160C
080-050-02250	Planetenrollermotor 201,4ccm-W:Ø40	MT200C
080-050-02300	Planetenrollermotor 251,8ccm-W:Ø40	MT250C
080-050-02350	Planetenrollermotor 326,3ccm-W:Ø40	MT315C
080-050-02400	Planetenrollermotor 410,9ccm-W:Ø40	MT400C
080-050-02450	Planetenrollermotor 523,6ccm-W:Ø40	MT500C
080-050-02500	Planetenrollermotor 612,3ccm-W:Ø40	MT630C
080-050-02550	Planetenrollermotor 725ccm-W:Ø40	MT725C

HYDRAULIC MOTORS MT



APPLICATION

- » Conveyors
- » Metal working machines
- » Machines for agriculture
- » Road building machines
- » Mining machinery
- » Food industries
- » Special vehicles
- » Plastic and rubber machinery etc.

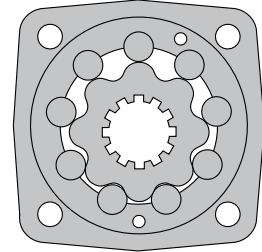

CONTENTS

Specification data	32
Function diagrams	33÷36
Dimensions and mounting	37
Shaft extensions	38
Permissible Shaft Seal pressure	38
Dimensions and mounting- MTS, V	39÷40
Internal Spline data	41
Permissible shaft loads	41
Tacho connection	42
Order code	42

OPTIONS

- » Model- Disc valve, roll-gerotor
- » Flange with wheel mount
- » Short motor
- » Tacho connection
- » Speed sensing
- » Side and rear ports
- » Shafts- straight, splined and tapered
- » Metric and BSPP ports
- » Other special features

GENERAL

Displacement, [cm ³ /rev.]	161,1 ÷ 725
Max. Speed, [RPM]	175 ÷ 625
Max. Torque, [daNm]	47 ÷ 125
Max. Output, [kW]	20,2 ÷ 33,5
Max. Pressure Drop, [bar]	115 ÷ 200
Max. Oil Flow, [l/min]	100 ÷ 125
Min. Speed, [RPM]	5 ÷ 10
Permissible Shaft Loads, [daN]	P ₀ = 1000
Pressure fluid	Mineral based- HLP(DIN 51524) or HM(ISO 6743/4)
Temperature range, [°C]	-30 ÷ 90
Optimal Viscosity range, [mm ² /s]	20 ÷ 75
Filtration	ISO code 20/16 (Min. recommended fluid filtration of 25 micron)

Oil flow in drain line

Pressure drop (bar)	Viscosity (mm ² /s)	Oil flow in drain line (l/min)
140	20	2,5
	35	1,5
210	20	5
	35	3

Pressure Losses

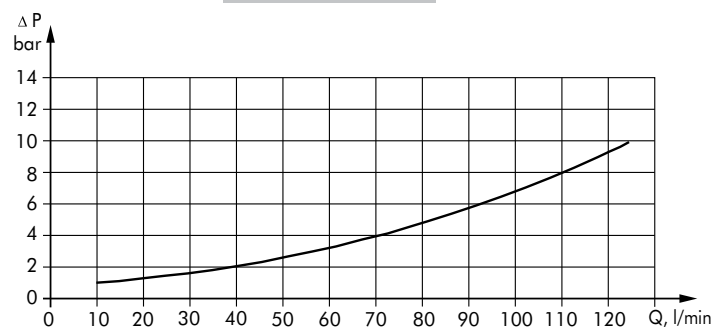

SPECIFICATION DATA

Type	MT 160	MT 200	MT 250	MT 315	MT 400	MT 500	MT 630	MT 725	
Displacement [cm ³ /rev.]	161,1	201,4	251,8	326,3	410,9	523,6	631,2	724,3	
Max. Speed, [RPM]	cont.	625	625	500	380	305	240	197	164
	Int.*	780	750	600	460	365	285	234	199
Max. Torque [daNm]	cont.	47	59	73	95	108	122	138	153
	Int.*	56	71	88	114	126	137	155	172
	peak**	66	82	102	133	144	160	180	200
Max. Output [kW]	cont.	26,5	33,5	33,5	33,5	30	26,5	24,3	20,2
	int.*	32	40	40	40	35	30	27,5	26,8
Max. Pressure Drop [bar]	cont.	200	200	200	200	180	160	140	120
	Int.*	240	240	240	240	210	180	160	140
	peak**	280	280	280	280	240	210	190	165
Max. Oil Flow [l/min]	cont.	100	125	125	125	125	125	125	125
	Int.*	125	150	150	150	150	150	151,4	151,4
Max. Inlet Pressure [bar]	cont.	210	210	210	210	210	210	210	210
	Int.*	250	250	250	250	250	250	250	250
	peak**	300	300	300	300	300	300	300	300
Max. Return Pressure with Drain Line [bar]	cont.	140	140	140	140	140	140	140	140
	Int.*	175	175	175	175	175	175	175	175
	peak**	210	210	210	210	210	210	210	210
Max. Starting Pressure with Unloaded Shaft, [bar]	10	10	10	10	10	10	10	10	
Min. Starting Torque [daNm]	at max. press. drop cont.	34	43	53	74	84	95	95	95
	at max. press. drop Int.*	41	52	63	89	97	106	110	115
Min. Speed***, [RPM]	10	9	8	7	6	5	5	5	
Weight, [kg] For Rear Ports +0,45 kg	MT	20	20,5	21	22	23	24	23,5	24,5
	MTW	22	22,5	23	24	25	26	25,5	26,5
	MTS	15	15,5	16	17	18	19	18,5	19,5
	MTV	11	11,5	12	13	14	15	14,5	15,5

* Intermittent operation: the permissible values may occur for max. 10% of every minute.

** Peak load: the permissible values may occur for max. 1% of every minute.

*** For speeds of 5 RPM lower than given, consult factory or your regional manager.

- 1) Intermittent speed and intermittent pressure must not occur simultaneously.
- 2) Recommended filtration is per ISO cleanliness code 20/16. A nominal filtration of 25 micron or better.
- 3) Recommend using a premium quality, anti-wear type mineral based hydraulic oil, HLP(DIN51524) or HM(ISO6743/4).
If using synthetic fluids consult the factory for alternative seal materials.
- 4) Recommended minimum oil viscosity 13 mm²/s at 50°C.
- 5) Recommended maximum system operating temperature is 82°C.
- 6) To assure optimum motor life fill with fluid prior to loading and run at moderate load and speed for 10-15 minutes.

FUNCTION DIAGRAMS

MT 160

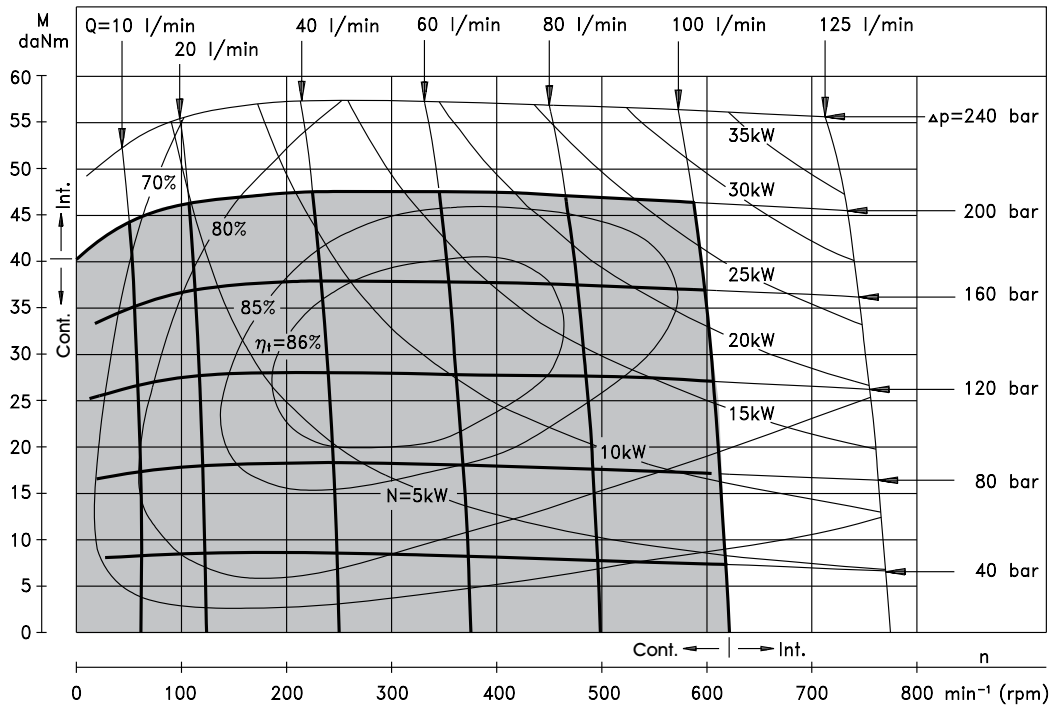

MT 200

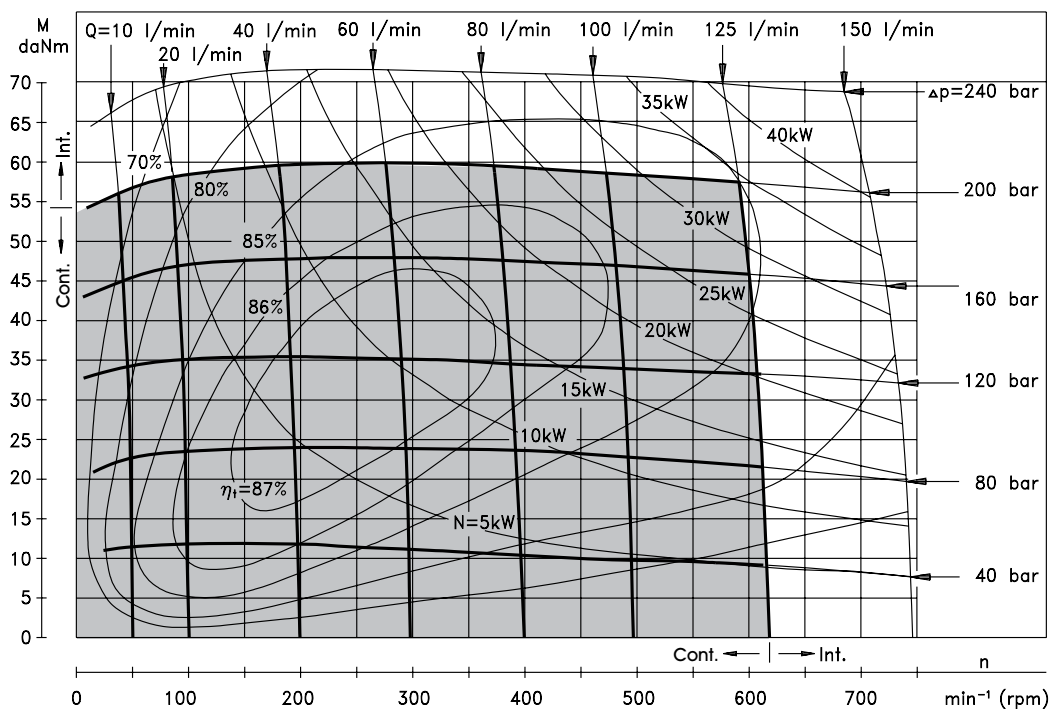

The function diagrams data was collected at back pressure 5 ÷ 10 bar and oil with viscosity of 32 mm^2/s at 50° C.

FUNCTION DIAGRAMS

MT 250

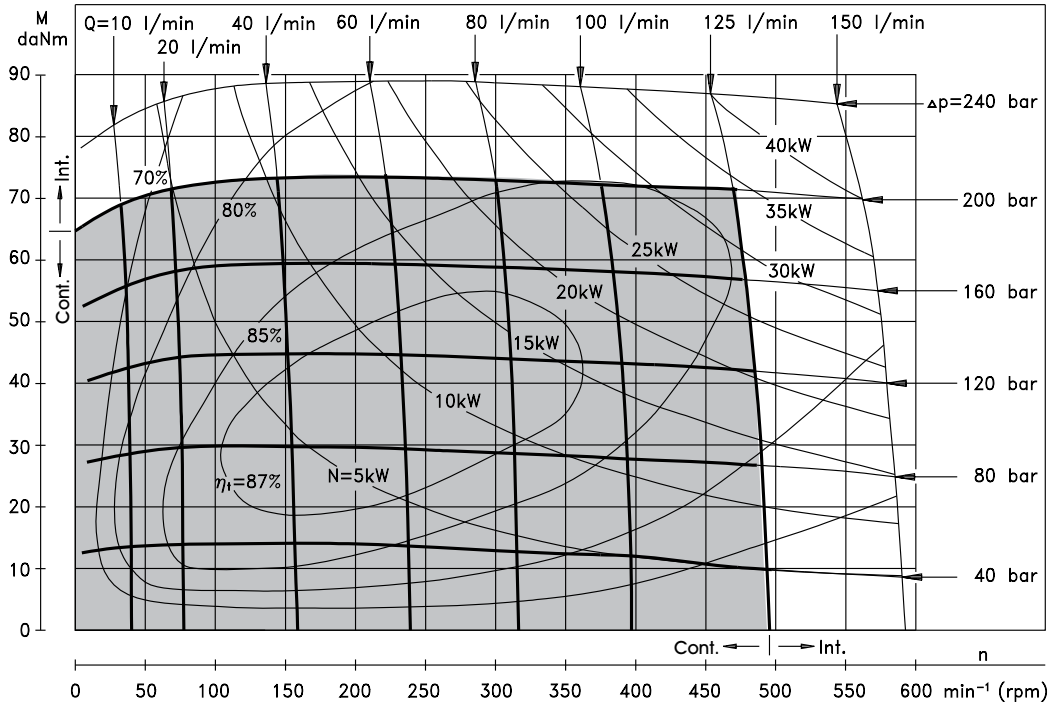

MT 315

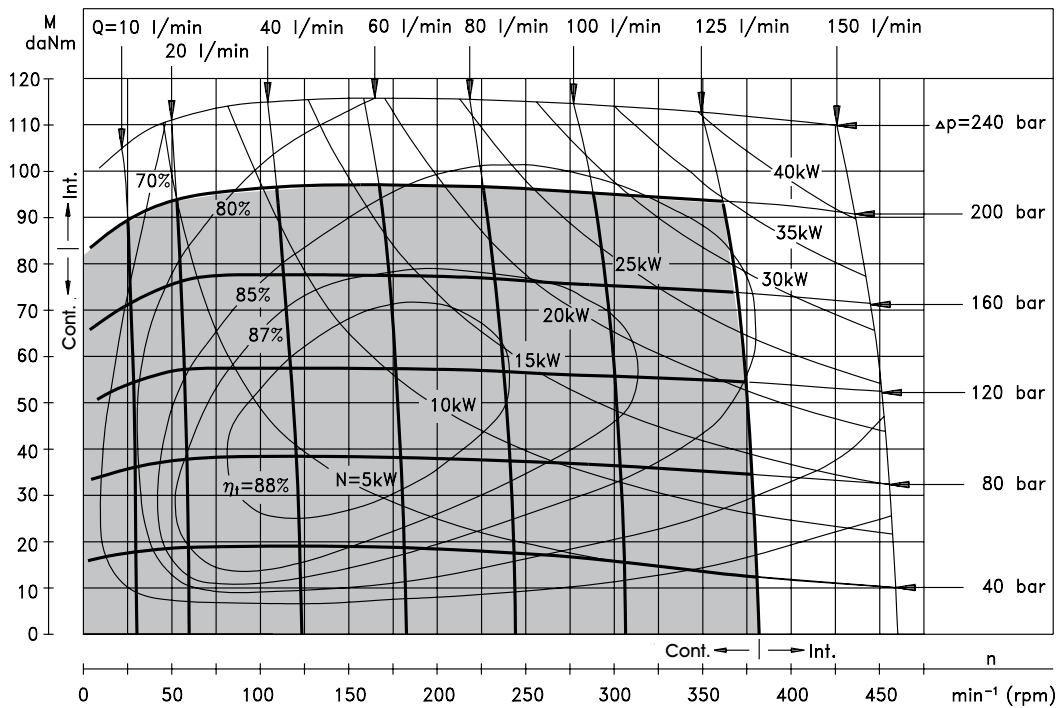

FUNCTION DIAGRAMS

MT 400

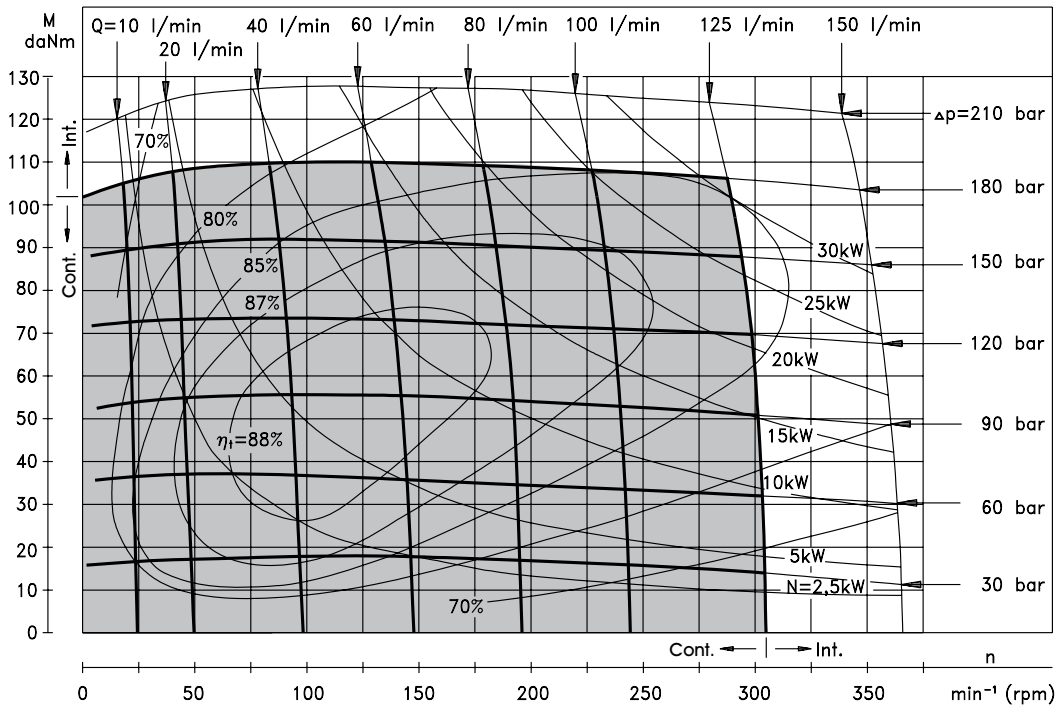

MT 500

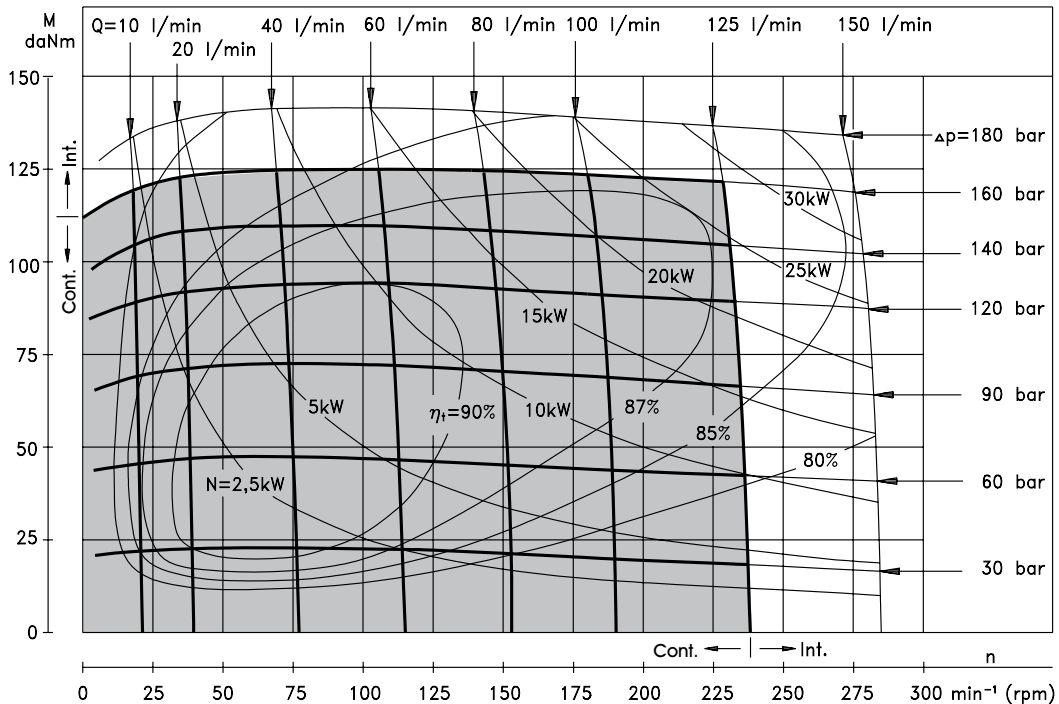

The function diagrams data was collected at back pressure 5 ÷ 10 bar and oil with viscosity of 32 mm^2/s at 50° C.

FUNCTION DIAGRAMS

MT 630

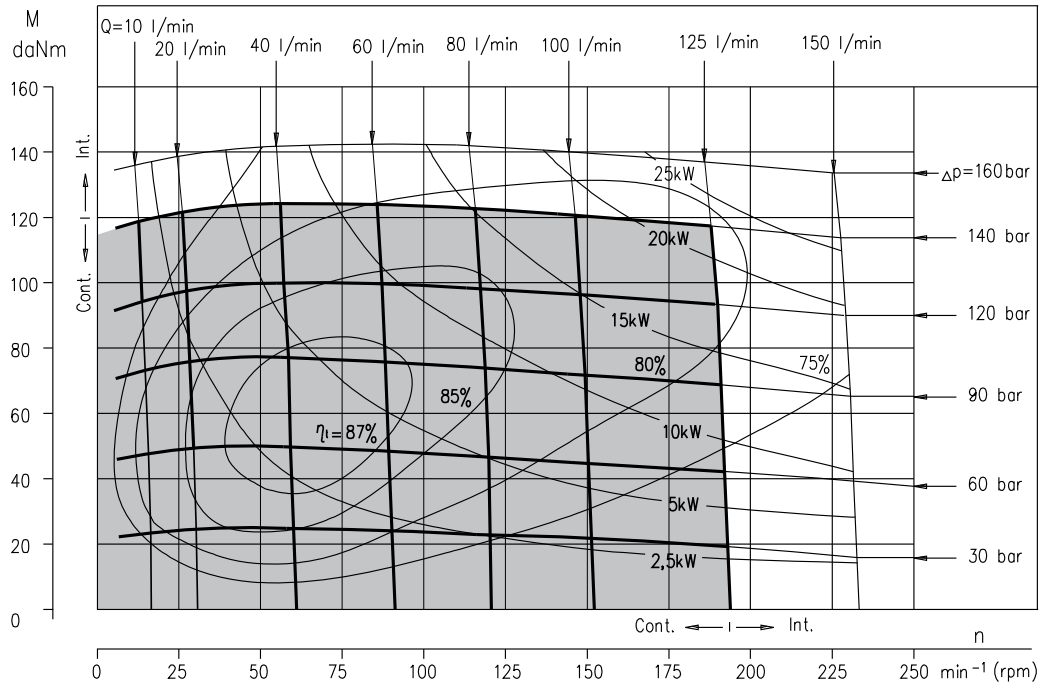

MT 725

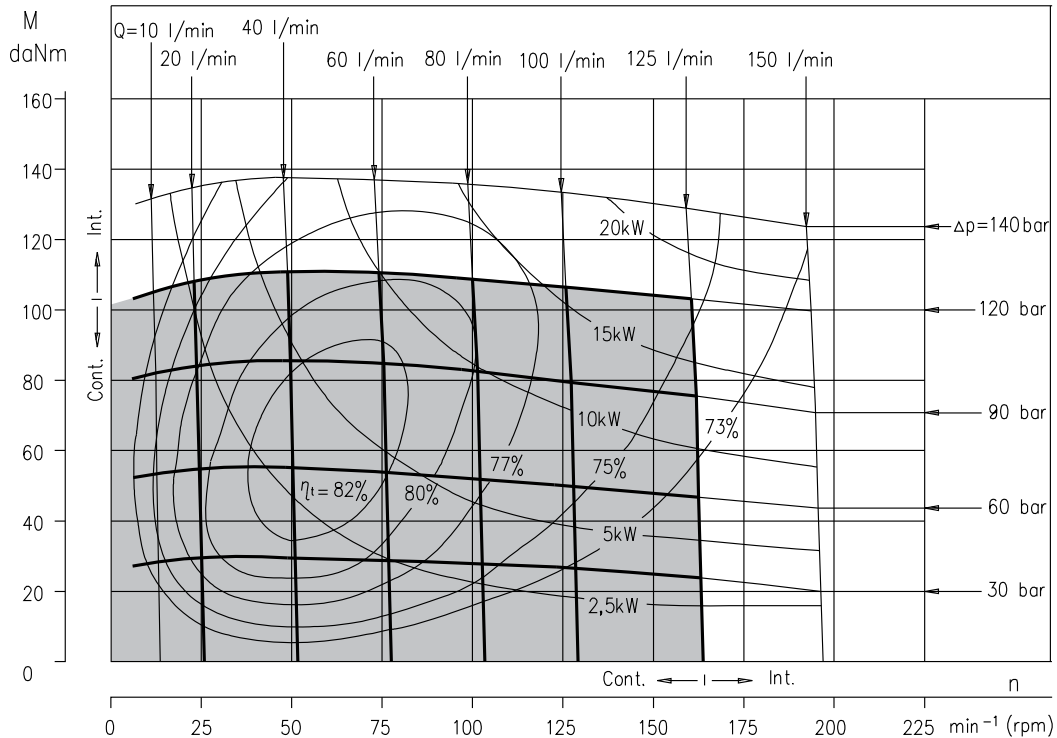

The function diagrams data was collected at back pressure 5±10 bar and oil with viscosity of 32 mm²/s at 50° C.

DIMENSIONS AND MOUNTING DATA

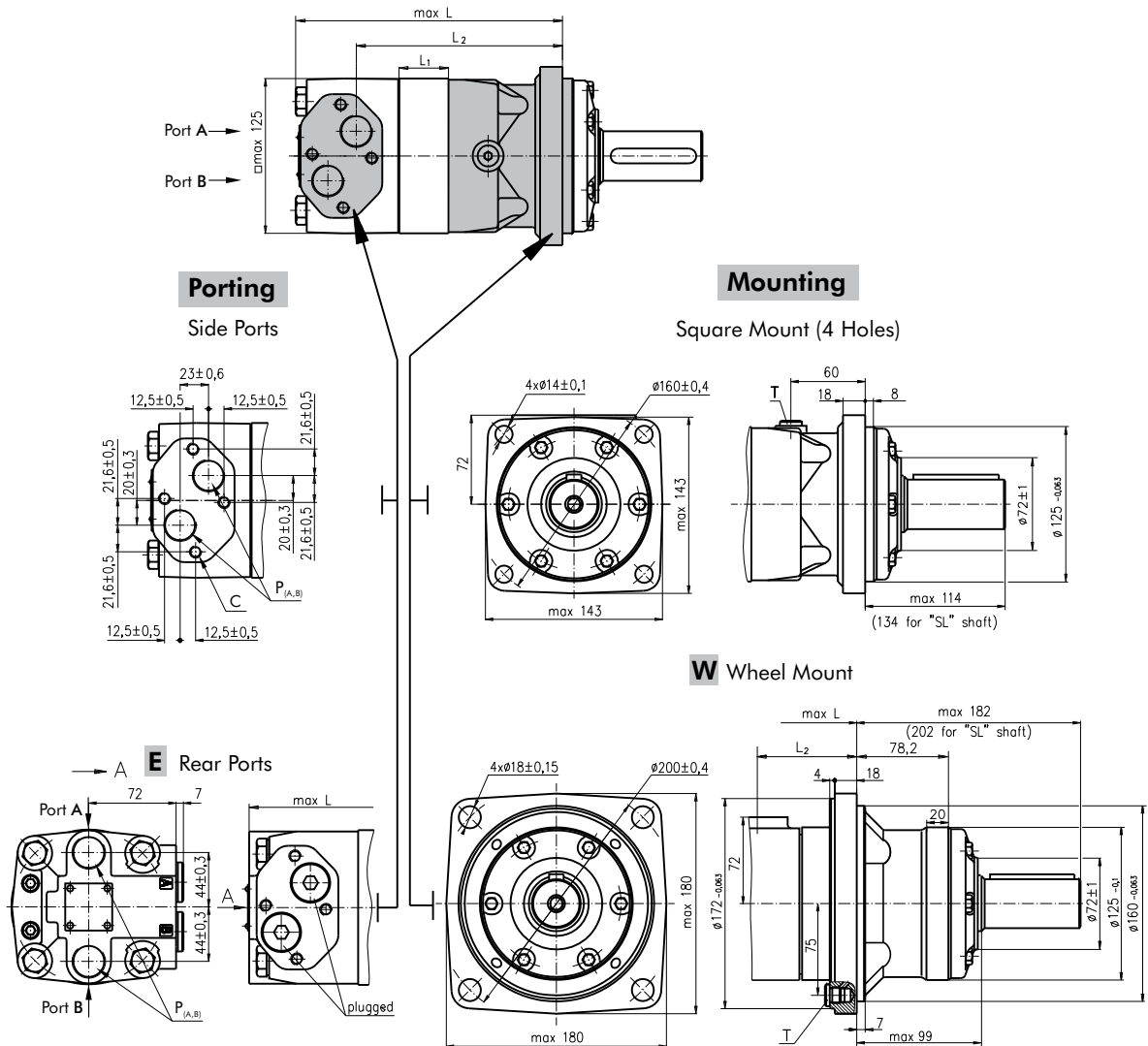

Standard Rotation
Viewed from Shaft End
Port A Pressurized - CW
Port B Pressurized - CCW

Reverse Rotation
Viewed from Shaft End
Port A Pressurized - CCW
Port B Pressurized - CW

C: 4xM10-10 mm depth
P_(A,B): 2xG3/4 or 2xM27x2-17 mm depth
T: G 1/4 or M14x1,5 - 12 mm depth (plugged)

Type	L, mm	Type	L, mm	L ₂ , mm	Type	L, mm	Type	L, mm	L ₂ , mm	*L ₁ , mm
MT 160	190	MTE 160	200	140	MTW 160	123	MTWE 160	133	73	16,5
MT 200	195	MTE 200	205	145	MTW 200	128	MTWE 200	138	78	21,5
MT 250	201	MTE 250	211	151	MTW 250	134	MTWE 250	144	84	27,8
MT 315	211	MTE 315	221	161	MTW 315	144	MTWE 315	154	94	37,0
MT 400	221	MTE 400	231	171	MTW 400	154	MTWE 400	164	104	47,5
MT 500	235	MTE 500	245	185	MTW 500	168	MTWE 500	178	118	61,5
MT 630	231	MTE 630	241	181	MTW 630	164	MTWE 630	174	114	57,5
MT 725	240	MTE 725	250	190	MTW 725	173	MTWE 725	183	123	66,5

* The width of the roll-gerotor is 3,5 mm greater than L₁.

SHAFT EXTENSIONS

C - $\varnothing 40$ straight, Parallel key A12x8x70 DIN 6885
Max. Torque 132,8 daNm

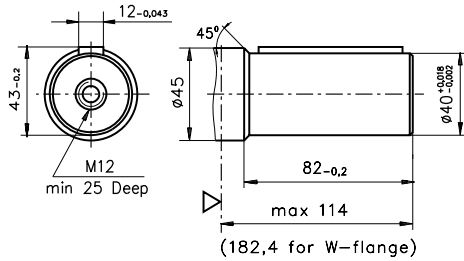

K -tapered 1:10, Parallel key B12x8x28 DIN 6885
Max. Torque 210,7 daNm

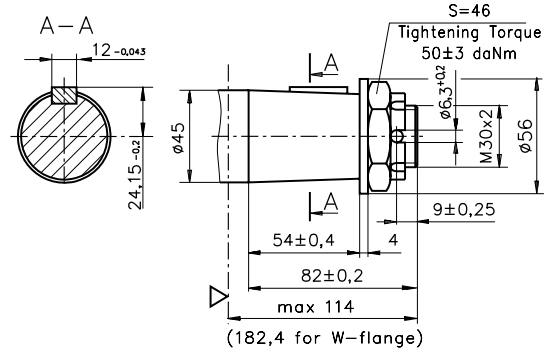

CO - $\varnothing 1\frac{1}{2}$ " straight, Parallel key $\frac{3}{8}$ "x $\frac{3}{8}$ "x $2\frac{1}{4}$ " BS46
Max. Torque 132,8 daNm

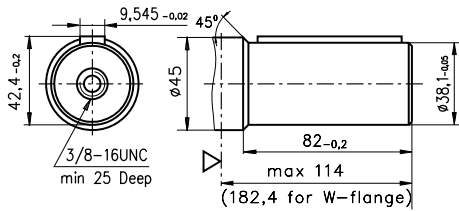

SH - $\varnothing 1\frac{1}{2}$ " splined 17T, DP 12/24 ANSI B92.1-1976
Max. Torque 132,8 daNm

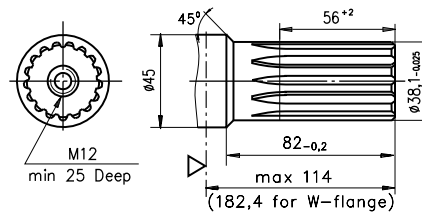

SL - $\varnothing 34,85$ p.t.o. DIN 9611 Form 1
Max. Torque 77 daNm

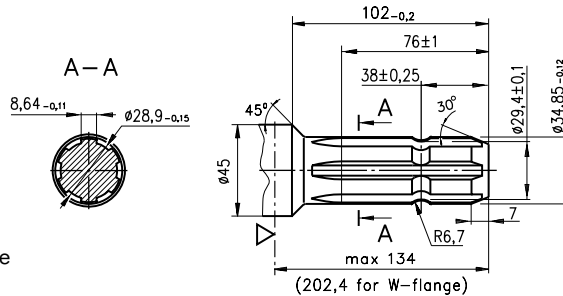

▽ - Motor Mounting Surface

MAX. PERMISSIBLE SHAFT SEAL PRESSURE for MT motors

**Max. return pressure without drain line or
max. pressure in the drain line**

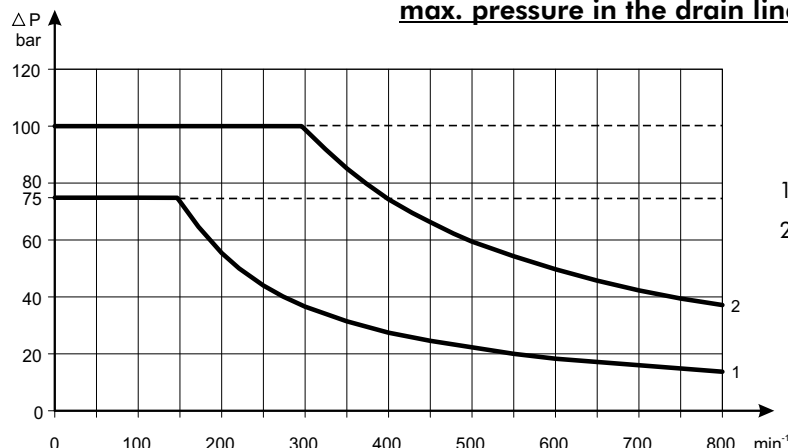

1: Drawing for Standard Shaft Seal

2: Drawing for High Pressure Seal ("U" Seal)

— - continuous operations
- - - - intermittent operations

DIMENSIONS AND MOUNTING DATA - MTS and MTV

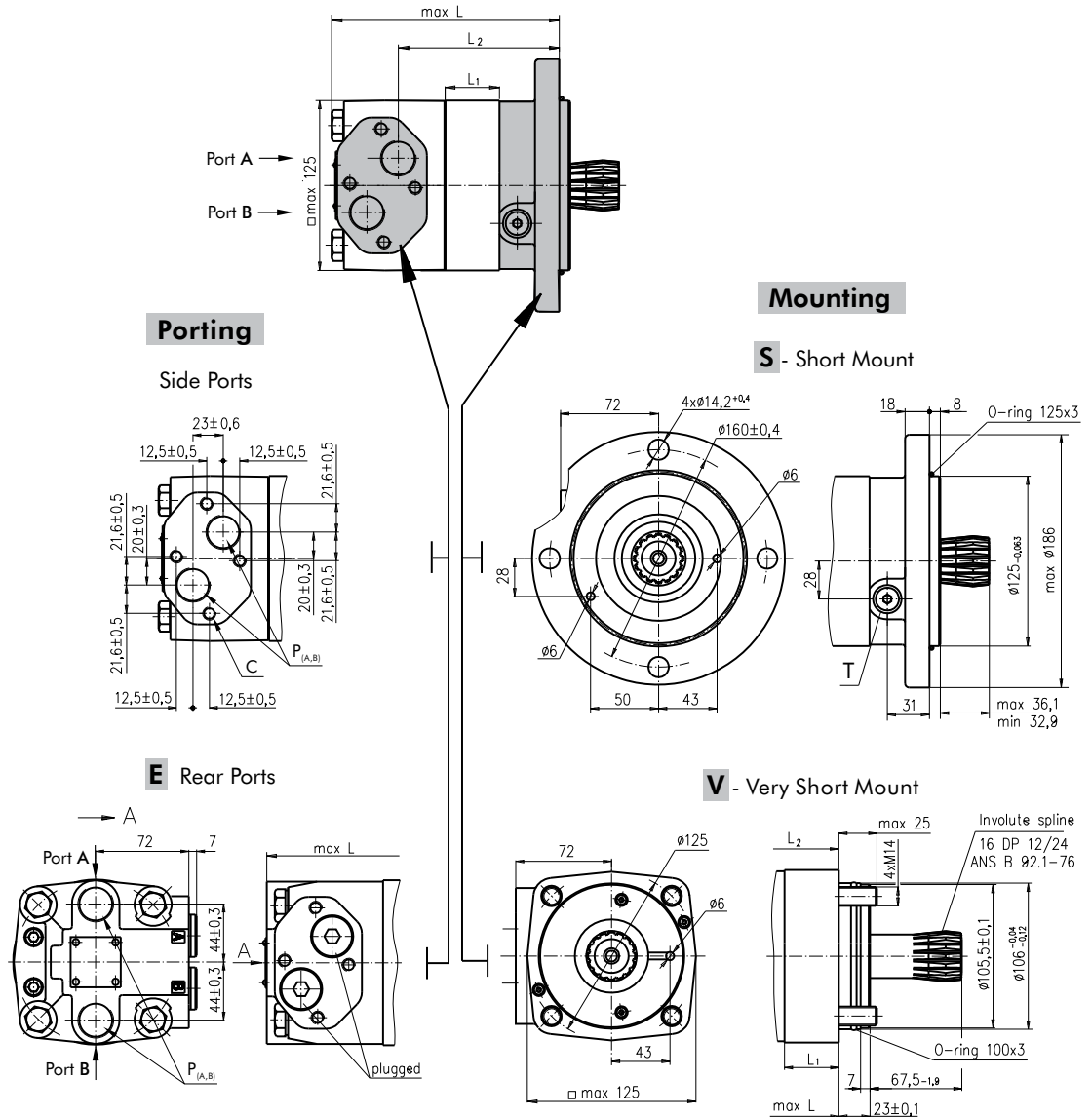

Standard Rotation
Viewed from Shaft End
Port A Pressurized - CW
Port B Pressurized - CCW

Reverse Rotation
Viewed from Shaft End
Port A Pressurized - CCW
Port B Pressurized - CW

C: 4xM10-10 mm depth
P_(A,B): 2xG3/4 or 2xM27x2-17 mm depth
T: G 1/4 or M14x1,5 - 12 mm depth (plugged)

Type	L, mm	Type	L, mm	L ₂ , mm	Type	L, mm	Type	L, mm	L ₂ , mm	*L ₁ , mm
MTS 160	146	MTSE 160	156	96	MTV 160	101	MTVE 160	111	51,5	16,5
MTS 200	151	MTSE 200	161	101	MTV 200	106	MTVE 200	116	56,5	21,5
MTS 250	157	MTSE 250	167	107	MTV 250	112	MTVE 250	122	62,8	27,8
MTS 315	166	MTSE 315	176	116	MTV 315	121	MTVE 315	131	72	37,0
MTS 400	177	MTSE 400	187	127	MTV 400	132	MTVE 400	142	82,5	47,5
MTS 500	191	MTSE 500	201	142	MTV 500	146	MTVE 500	156	96,5	61,5
MTS 630	187	MTSE 630	197	138	MTV 630	142	MTVE 630	152	92,5	57,5
MTS 725	196	MTSE 725	206	147	MTV 725	151	MTVE 725	161	101,5	66,5

* The width of the roll-gerotor is 3,5 mm greater than L₁.

DIMENSIONS OF THE ATTACHED COMPONENT

MTS

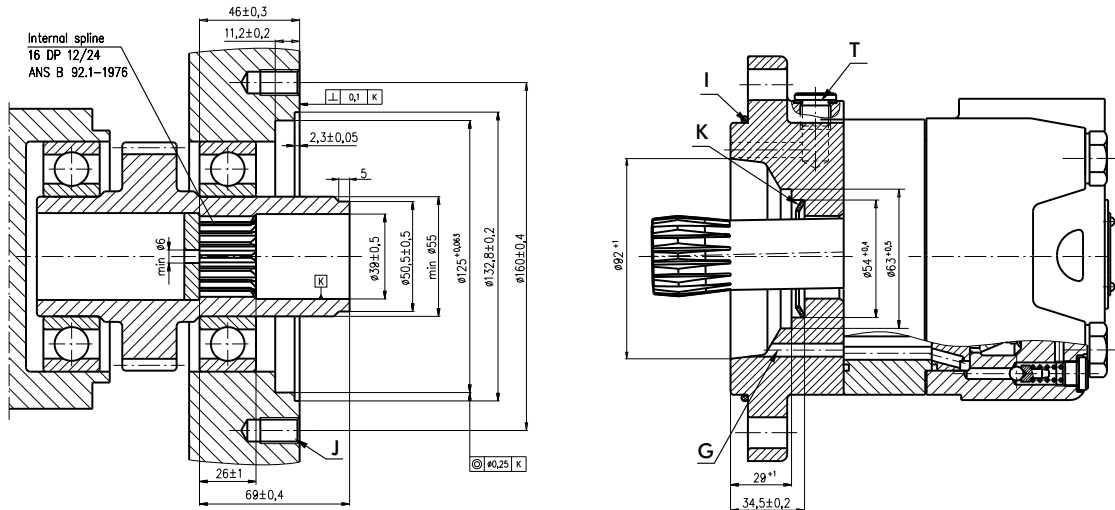

F: Oil circulation hole
G: Internal drain channel
H: Hardened stop plate

I: O- Ring 125x3mm
J: 4xM12-18 mm depth, 90°
K: Conical seal ring
T: Drain connection G1/4 or M14x1,5

MTV

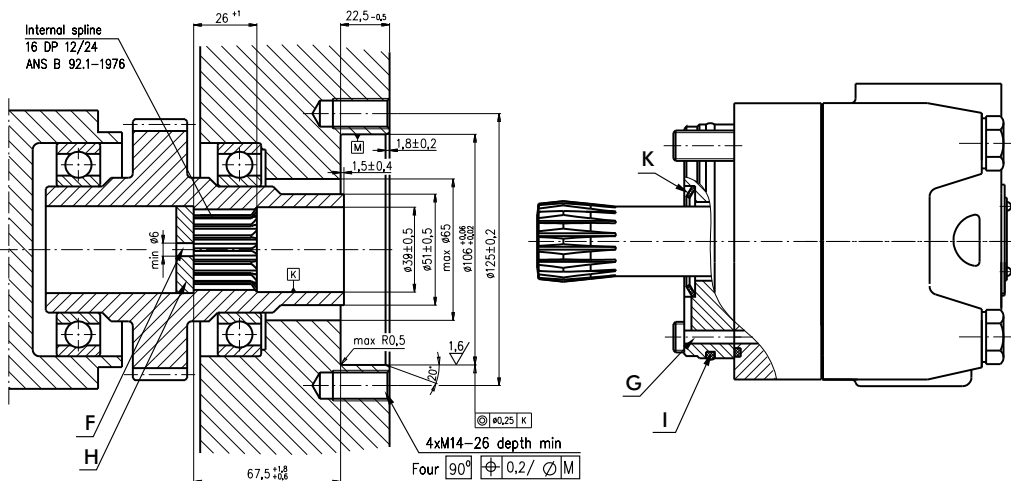

F: Oil circulation hole
G: Internal drain channel

H: Hardened stop plate
I: O- Ring 100x3mm
K: Conical seal ring

DRAIN CONNECTION

A drain line ought to be used when pressure in the return line can exceed the permissible pressure. It can be connected:

- For MTS at the drain port of the motor;
- For MTV at the drain connection of the attached component. The maximum pressure in the drain line is limited by the attached component and its shaft seal.

The drain line must be possible for oil to flow freely between motor and attached component and must be led to the tank. The maximum pressure in the drain line is limited by the attached component and its seal.

INTERNAL SPLINE DATA FOR THE ATTACHED COMPONENT

Standard ANS B92.1-1976, class 5
[$m=2.1166$; corrected $x.m=+1,0$]

Fillet Root Side Fit		mm
Number of Teeth	z	16
Diametral Pitch	DP	12/24
Pressure Angle		30°
Pitch Dia.	D	33,8656
Major Dia.	D _{ri}	38,4 ^{+0,4}
Minor Dia.	D _i	32,15 ^{+0,04}
Space Width [Circular]	Lo	4,516±0,037
Fillet Radius	R	0,5
Max. Measurement between Pin	L	26,9 ^{+0,10}
Pin Dia.	d	4,835±0,001

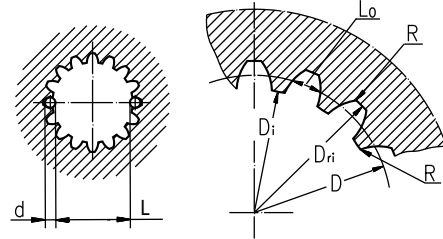

Hardening Specification:
 HV=750±50 on the surface
 HV=560 at 0,7±0,2 mm case depth
 Material 20 MoCr4 EN 10084 or better

PERMISSIBLE SHAFT LOADS

The output shaft runs in tapered bearings that permit high axial and radial forces. Curve "1" shows max. radial shaft load. Any shaft load exceeding the values quoted in the curve will seriously reduce motor life. The two other curves apply to a B10 bearing life of 3000 hours at 200 RPM.

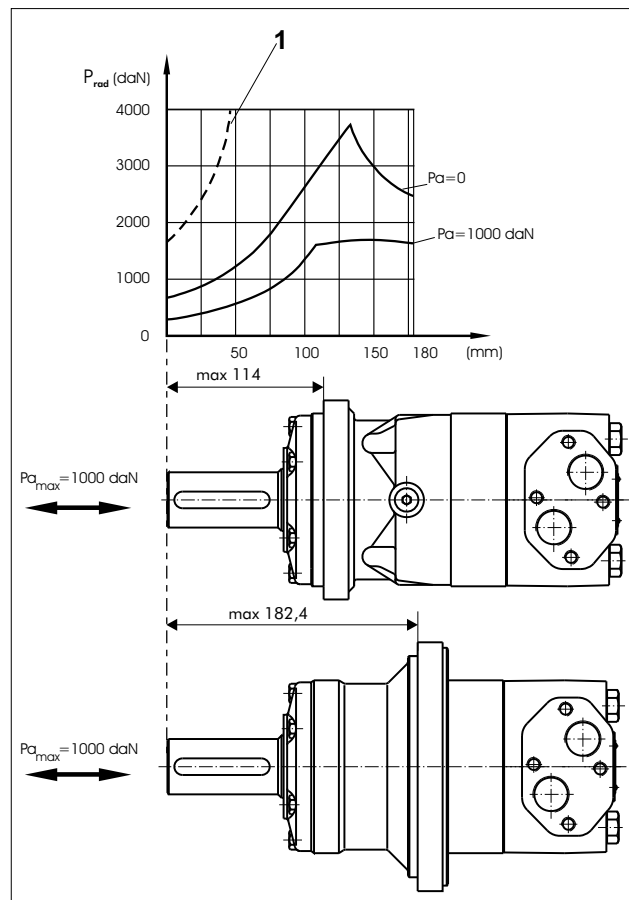

MOTORS WITH TACHO CONNECTION

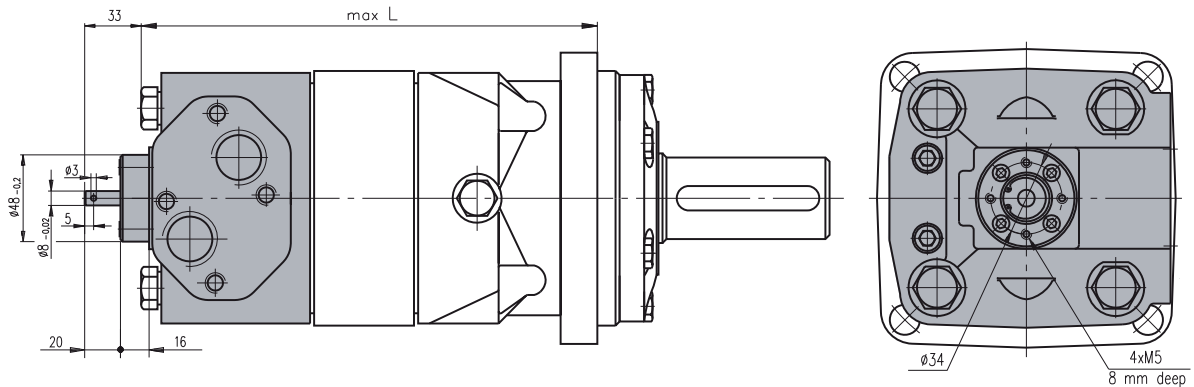

ORDER CODE

	1	2	3	4	5	6	7	8
MT								

Pos.1 - Mounting Flange

omit - Square mount, four holes

S - Short mount

V - Very short mount

W - Wheel mount

Pos.2 - Port type

omit - Side ports

E - Rear ports

Pos.3 - Displacement code

160 - 161,1 [cm³/rev]

200 - 201,4 [cm³/rev]

250 - 251,8 [cm³/rev]

315 - 326,3 [cm³/rev]

400 - 410,9 [cm³/rev]

500 - 523,6 [cm³/rev]

630 - 631,2 [cm³/rev]

725 - 724,3 [cm³/rev]

Pos.4 - Shaft Extensions*

omit - for **S** and **V** mounting flange

C - $\varnothing 40$ straight, Parallel key A12x8x70 DIN6885

CO - $\varnothing 1\frac{1}{2}$ " straight, Parallel key $\frac{3}{8}$ "x $\frac{3}{8}$ "x $2\frac{1}{4}$ " BS46

K - $\varnothing 45$ tapered 1:10, Parallel key B12x8x28 DIN6885

SL - $\varnothing 34,85$ p.t.o. DIN 9611 Form 1

SH - $\varnothing 1\frac{1}{2}$ " splined 17T ANS B92.1-1976

Pos.5 - Shaft Seal Version (see page 38)

omit - Low pressure seal

U - High pressure seal

Pos.6 - Ports

omit - BSPP (ISO 228)

M - Metric (ISO 262)

Pos.7 - Special Features (see page 65)

Pos.8 - Design Series

omit - Factory specified

NOTES:

* The permissible output torque for shafts must not be exceeded!

The hydraulic motors are mangano-phosphatized as standard.