

PL 01 T E

POLARIS®

Hydraulic gear pumps and motors

through bore aluminum body

DISPLACEMENTS

From 0.07 in³/rev
(1.07 cm³/rev)
To 5.56 in³/rev
(91.10 cm³/rev)

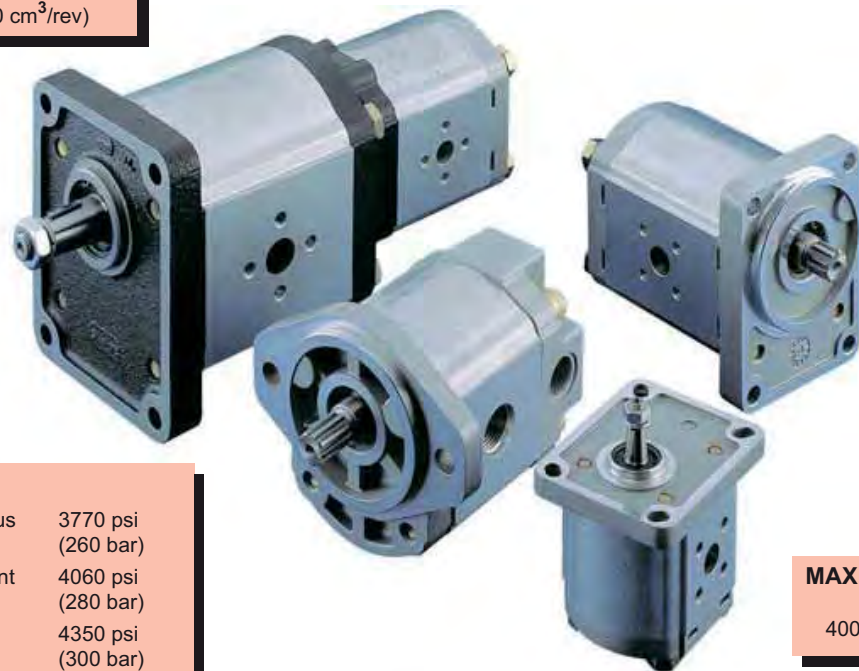

PRESSURE

Max. Continuous 3770 psi
(260 bar)
Max. Intermittent 4060 psi
(280 bar)
Max. Peak 4350 psi
(300 bar)

MAX. SPEED

4000 min⁻¹

- Group 1, 2 and 3 with displacements from 0.07 in³/rev (1,07 cm³/rev) to 5.56 in³/rev (91.10 cm³/rev).
- Drive shafts, mounting flanges and ports according to the international standards.
- Combination of multiple pumps in standard version, common inlet and separated stages.
- Integrated outboard bearings for heavy duty application.
- Many types of built-in valves.

"POLARIS" more than fifty years of Casappa experience in design and production of hydraulic components, characterized by large investments in research and development in order to propose new and personalized solutions to the market. Our use of CAD 3D in the development of this generation permit us the 3D modelling and the virtual simulation of the behaviour of the components inserted in the hydraulic circuit. This means that the process will take less time and the quality of the products is better. Polaris pumps and motors are basically composed of a gear housing in aluminium alloy, two gear wheels supported by sleeve bearings and two end plates, the front and the rear cover, either in aluminium or in cast iron with excellent mechanical characteristics. Our success is based largely on the quality of our product. This guaranties the consistencies of the efficiencies and low level of noise emission during the life of our products.

Edition: 01/10.2003



CASAPPA®
FLUID POWER DESIGN



FEATURES

Construction	External gear type pumps and motors
Mounting	EUROPEAN - SAE - GERMAN standard flanges
Line connection	Screw and flange
Direction of rotation (looking on drive shaft)	Anti-clock (S) - clockwise (D) - reversible external drain (L - R) reversible internal drain (B)
Inlet pressure range for pumps	10 ÷ 44 psi [0,7 ÷ 3 bar (abs.)]
Max back pressure for single rotation motors and reversible internal drain motors	p_1 (continuous) max 73 psi (5 bar)
	p_2 (for 20 s) max 116 psi (8 bar)
	p_3 (for 8 s) max 218 psi (15 bar)
Max drain line pressure on the reversible rotation motors	73 psi (5 bar)
Max back pressure on the series motors (reversible motors external drain)	$< p_1$ (max continuous pressure) < 2175 psi (< 150 bar)
Fluid temperature range	See table (1)
Fluid	Mineral oil based hydraulic fluids to ISO/DIN. For other fluids please consult our technical sales department.
Viscosity range	From 60 to 456 SSU [12 to 100 mm ² /s (cSt)] recommended
	Up to 3410 SSU [750 mm ² /s (cSt)] permitted
Filtering requirement	See table (2) page 4

Type	Fluid composition	Max pressure psi - (bar)	Max speed [min ⁻¹]	Temperature °F - (°C)	Seals (●)	Special shaft seals (◆)
ISO/DIN	Mineral oil based hydraulic fluid to ISO/DIN	See page 5	See page 5	-13 ÷ +176 (-25 ÷ +80)	N	D - H - C
				-13 ÷ +230 (-25 ÷ +110)	V	D

(●) N= Buna N (standard) - V= Viton

◆ Shaft seals max pressure and mounting scheme

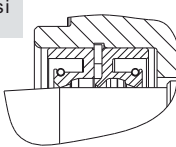
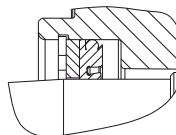
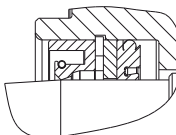
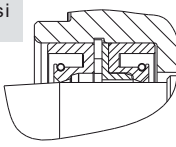
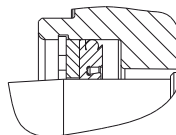
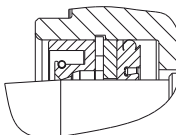
	D	H	C
	Standard shaft seal with wiper seal	High pressure special shaft seal	High pressure special shaft seal with wiper seal
Single rotation pumps	Max 44 psi (3 bar) DCAT_033_037 	Max 363 psi (25 bar) # DCAT_033_039 	Max 363 psi (25 bar) # DCAT_033_036 
Single rotation motors Reversible rotation pumps and motors	Max 44 psi (3 bar) DCAT_033_038 	DCAT_033_039 	DCAT_033_036 

Pressure could change in connection with shaft speed rotation.
For more information please consult our technical sales department.

01/10.03

FEATURES

Filtration

Tab. 2

Working pressure	$\Delta p > 2900 \text{ psi} - (200 \text{ bar})$	$\Delta p < 2900 \text{ psi} - (200 \text{ bar})$
Contamination class NAS 1638	8	10
Contamination class ISO 4406	19/17/14	21/19/16
Achieved with filter $\beta_{x \geq 75}$	10 μm	25 μm

Casappa recommends to use its own production filters:



General notes

Available with different inlet and outlet ports.
For more information please consult our technical sales department.

Definition of rotation direction looking on the drive shaft

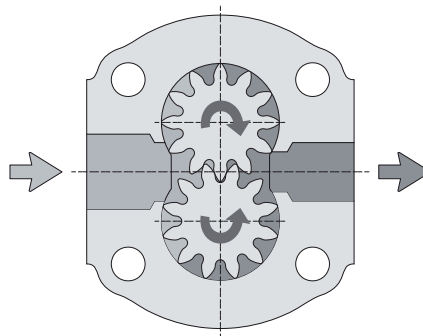
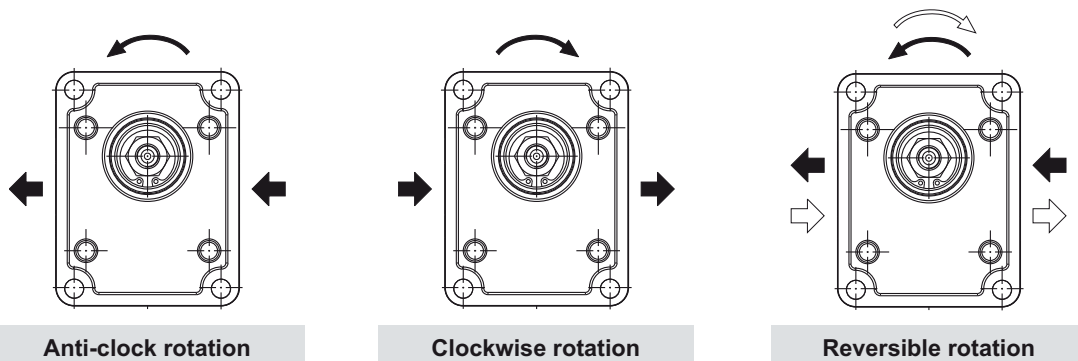

Pressure definition

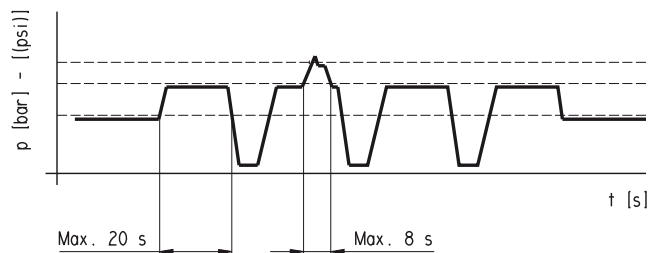

p_1 Max. continuous pressure
 p_2 Max. intermittent pressure
 p_3 Max. peak pressure

01/10.03

GENERAL DATA PUMPS AND MOTORS

Series	Pump type PLP Motor type PLM	Displacement in ³ /rev (cm ³ /rev)	Max. pressure			Max. speed	Min. speed
			p ₁	p ₂	p ₃		
			psi (bar)				
POLARIS 10	PL. 10•1	0.07 (1,07)	3770 (260)	4060 (280)	4205 (290)	4000	650
	PL. 10•1,5	0.10 (1,60)	3770 (260)	4060 (280)	4205 (290)	4000	650
	PL. 10•2	0.13 (2,13)	3770 (260)	4060 (280)	4205 (290)	4000	650
	PL. 10•2,5	0.16 (2,67)	3770 (260)	4060 (280)	4205 (290)	4000	650
	PL. 10•3,15	0.20 (3,34)	3770 (260)	4060 (280)	4205 (290)	4000	650
	PL. 10•4	0.26 (4,27)	3625 (250)	3915 (270)	4060 (280)	4000	650
	PL. 10•5	0.33 (5,34)	3625 (250)	3915 (270)	4060 (280)	4000	650
	PL. 10•5,8	0.38 (6,20)	3335 (230)	3625 (250)	3770 (260)	3500	650
	PL. 10•6,3	0.41 (6,67)	3335 (230)	3625 (250)	3770 (260)	3500	650
	PL. 10•8	0.52 (8,51)	2610 (180)	2900 (200)	3045 (210)	3500	650
	PL. 10•10	0.65 (10,67)	2030 (140)	2320 (160)	2465 (170)	3500	650
POLARIS 20	PL. 20•4	0.30 (4,95)	3625 (250)	4060 (280)	4350 (300)	4000	600
	PL. 20•6,3	0.40 (6,61)	3625 (250)	4060 (280)	4350 (300)	4000	600
	PL. 20•7,2	0.44 (7,29)	3625 (250)	4060 (280)	4350 (300)	4000	600
	PL. 20•8	0.50 (8,26)	3625 (250)	4060 (280)	4350 (300)	3500	600
	PL. 20•9	0.56 (9,17)	3625 (250)	4060 (280)	4350 (300)	3500	600
	PL. 20•10,5	0.66 (10,9)	3625 (250)	4060 (280)	4350 (300)	3500	600
	PL. 20•11,2	0.69 (11,23)	3625 (250)	4060 (280)	4350 (300)	3500	600
	PL. 20•14	0.89 (14,53)	3625 (250)	4060 (280)	4350 (300)	3500	500
	PL. 20•16	1.03 (16,85)	3625 (250)	4060 (280)	4350 (300)	3000	500
	PL. 20•19	1.16 (19,09)	2900 (200)	3190 (220)	3480 (240)	3000	500
	PL. 20•20	1.29 (21,14)	2900 (200)	3190 (220)	3480 (240)	3000	500
	PL. 20•24,5	1.52 (24,84)	2465 (170)	2755 (190)	3045 (210)	2500	500
	PL. 20•25	1.61 (26,42)	2465 (170)	2755 (190)	3045 (210)	2500	500
	PL. 20•27,8	1.72 (28,21)	1885 (130)	2175 (150)	2465 (170)	2000	500
PL. 20•31,5	2.01 (33,03)	1885 (130)	2175 (150)	2465 (170)	2000	500	
POLARIS 30	PL. 30•22	1.34 (21,99)	3625 (250)	3915 (270)	4060 (280)	3000	350
	PL. 30•27	1.63 (26,70)	3625 (250)	3915 (270)	4060 (280)	3000	350
	PL. 30•34	2.11 (34,55)	3480 (240)	3770 (260)	3915 (270)	3000	350
	PL. 30•38	2.40 (39,27)	3480 (240)	3770 (260)	3915 (270)	3000	350
	PL. 30•43	2.68 (43,98)	3335 (230)	3625 (250)	3770 (260)	3000	350
	PL. 30•51	3.16 (51,83)	3045 (210)	3335 (230)	3480 (240)	2500	350
	PL. 30•61	3.74 (61,26)	2755 (190)	3045 (210)	3190 (220)	2500	350
	PL. 30•73	4.50 (73,82)	2465 (170)	2755 (190)	2900 (200)	2500	350
	PL. 30•82	4.98 (81,68)	2320 (160)	2465 (170)	2610 (180)	2200	350
PL. 30•90	5.56 (91,10)	2175 (150)	2320 (160)	2465 (170)	2200	350	

p₁= Max. continuous pressure p₂= Max. intermittent pressure p₃= Max. peak pressure

The values in the table refer to unidirectional pumps and motors.
Reversible pump and motors max pressures are 15% lower than those shown in table.
For different working conditions please consult our sales department.

01/10.03

GENERAL DATA PUMPS AND MOTORS

Q	US gpm (l/min)	Flow
M	lbf in (Nm)	Torque
P	HP (kW)	Power
V	in ³ /rev (cm ³ /rev)	Displacement
n	min ⁻¹	Speed
Δp	psi (bar)	Pressure

Efficiencies

		Pumps	Motors
$\eta_v = \eta_v(V, \Delta p, n)$	Volumetric efficiency	($\approx 0,97$)	($\approx 0,96$)
$\eta_m = \eta_m(V, \Delta p, n)$	Mechanical efficiency	($\approx 0,88$)	($\approx 0,85$)
$\eta_t = \eta_v \cdot \eta_m$	Overall efficiency	($\approx 0,85$)	($\approx 0,82$)

DESIGN CALCULATIONS FOR PUMP

$$Q = V(\text{cm}^3/\text{rev}) \cdot \eta_v \cdot n \cdot 10^{-3} \quad [\text{l/min}]$$

$$M = \frac{\Delta p (\text{bar}) \cdot V (\text{cm}^3/\text{rev})}{62,83 \cdot \eta_m} \quad [\text{Nm}]$$

$$P = \frac{\Delta p (\text{bar}) \cdot V (\text{cm}^3/\text{rev}) \cdot n}{600 \cdot 1000 \cdot \eta_t} \quad [\text{kW}]$$

DESIGN CALCULATIONS FOR MOTOR

$$Q = \frac{V (\text{cm}^3/\text{rev}) \cdot n \cdot 10^{-3}}{\eta_v} \quad [\text{l/min}]$$

$$M = \frac{\Delta p (\text{bar}) \cdot V (\text{cm}^3/\text{rev}) \cdot \eta_m}{62,83} \quad [\text{Nm}]$$

$$P = \frac{\Delta p (\text{bar}) \cdot V (\text{cm}^3/\text{rev}) \cdot n \cdot \eta_t}{600 \cdot 1000} \quad [\text{kW}]$$

Note: Diagrams providing approximate selection data will be found on subsequent pages.

01/10.03

POLARIS 30 GEAR MOTORS PERFORMANCE CURVES

PLM 30

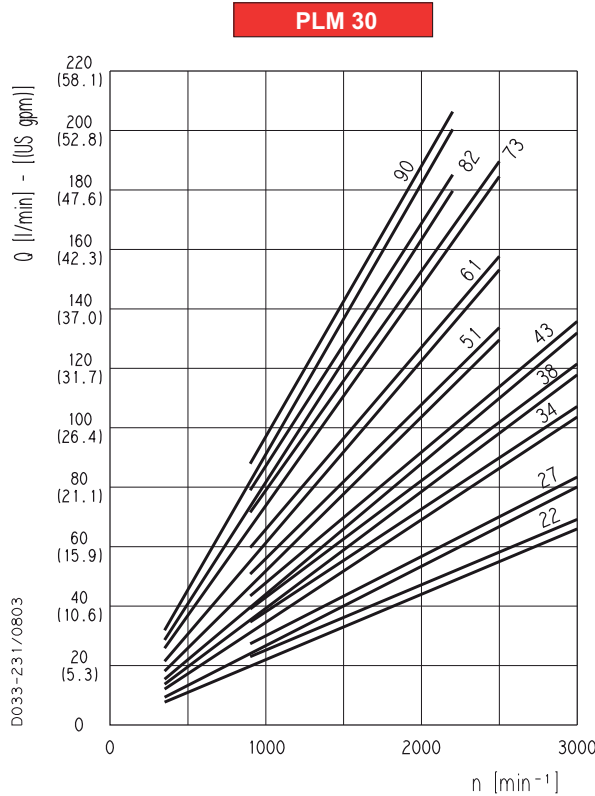

Each curve has been obtained at 122 °F (50°C), using oil with viscosity 168 SSU (36 cSt) at 104 °F (40°C) and at these pressures.

- PLM 30•22 . . . 290-3625 psi (20-250 bar)
- PLM 30•27 . . . 290-3625 psi (20-250 bar)
- PLM 30•34 . . . 290-3480 psi (20-240 bar)
- PLM 30•38 . . . 290-3480 psi (20-240 bar)
- PLM 30•43 . . . 290-3335 psi (20-230 bar)
- PLM 30•51 . . . 290-3045 psi (20-210 bar)
- PLM 30•61 . . . 290-2775 psi (20-190 bar)
- PLM 30•73 . . . 290-2465 psi (20-170 bar)
- PLM 30•82 . . . 290-2320 psi (20-160 bar)
- PLM 30•90 . . . 290-2175 psi (20-150 bar)

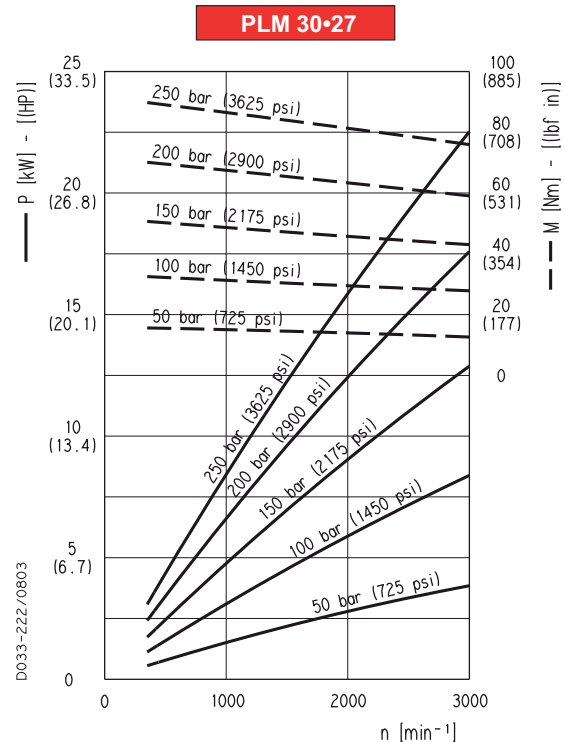
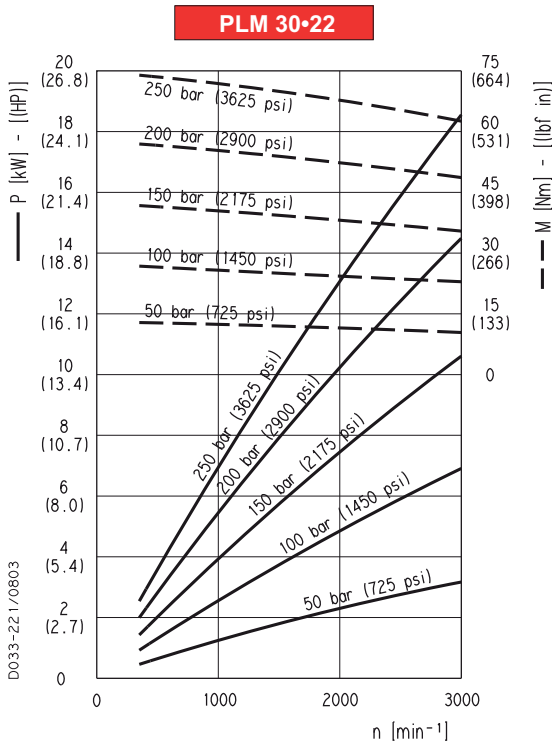

01/10.03

POLARIS 30 GEAR MOTORS PERFORMANCE CURVES

PLM 30

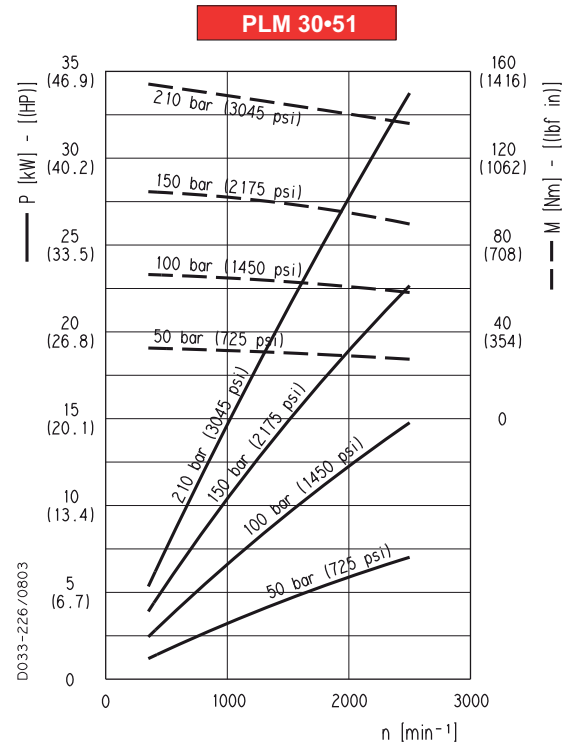
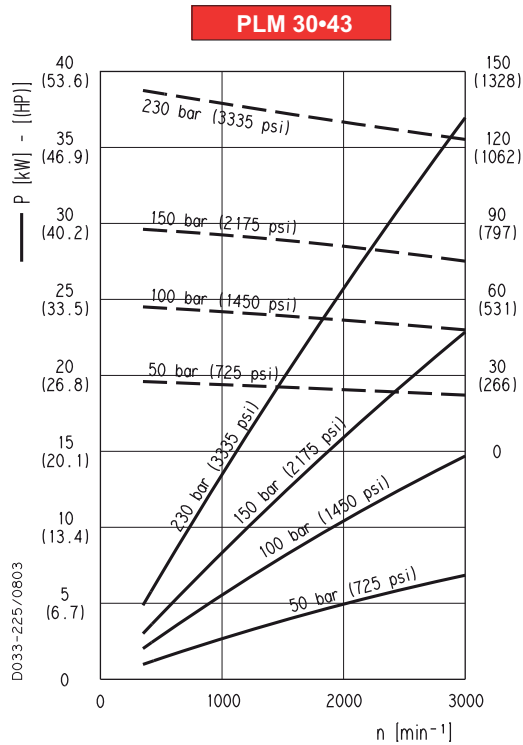
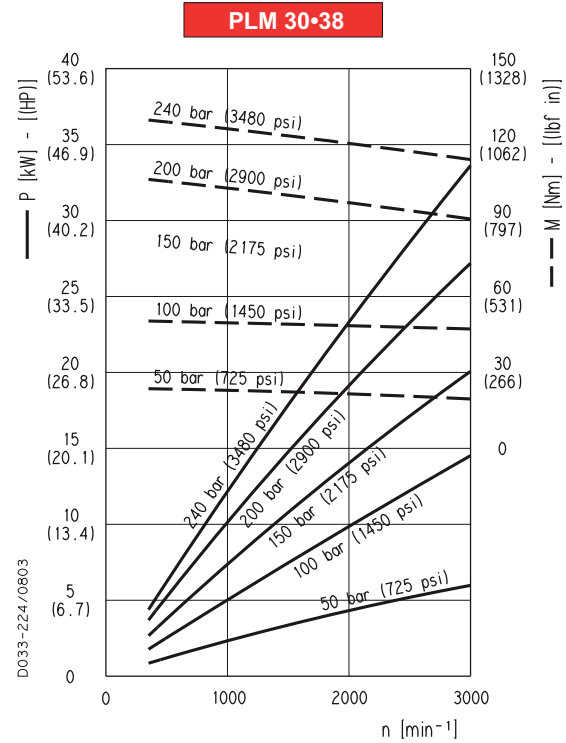
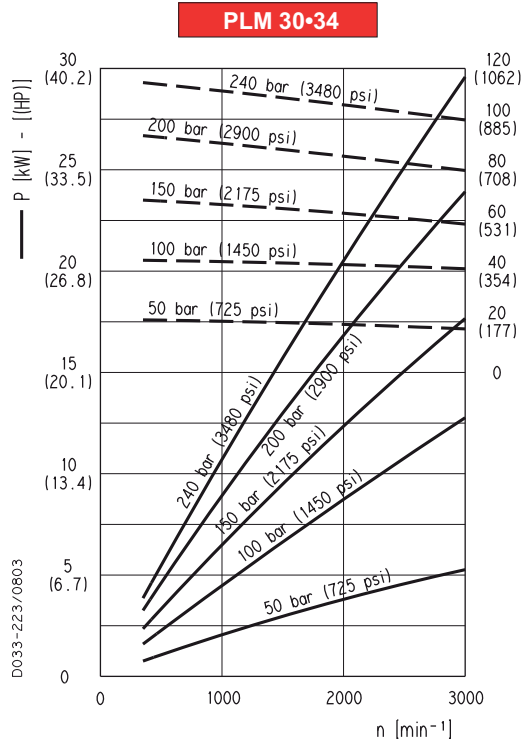

01/10.03

POLARIS 30 GEAR MOTORS PERFORMANCE CURVES

PLM 30

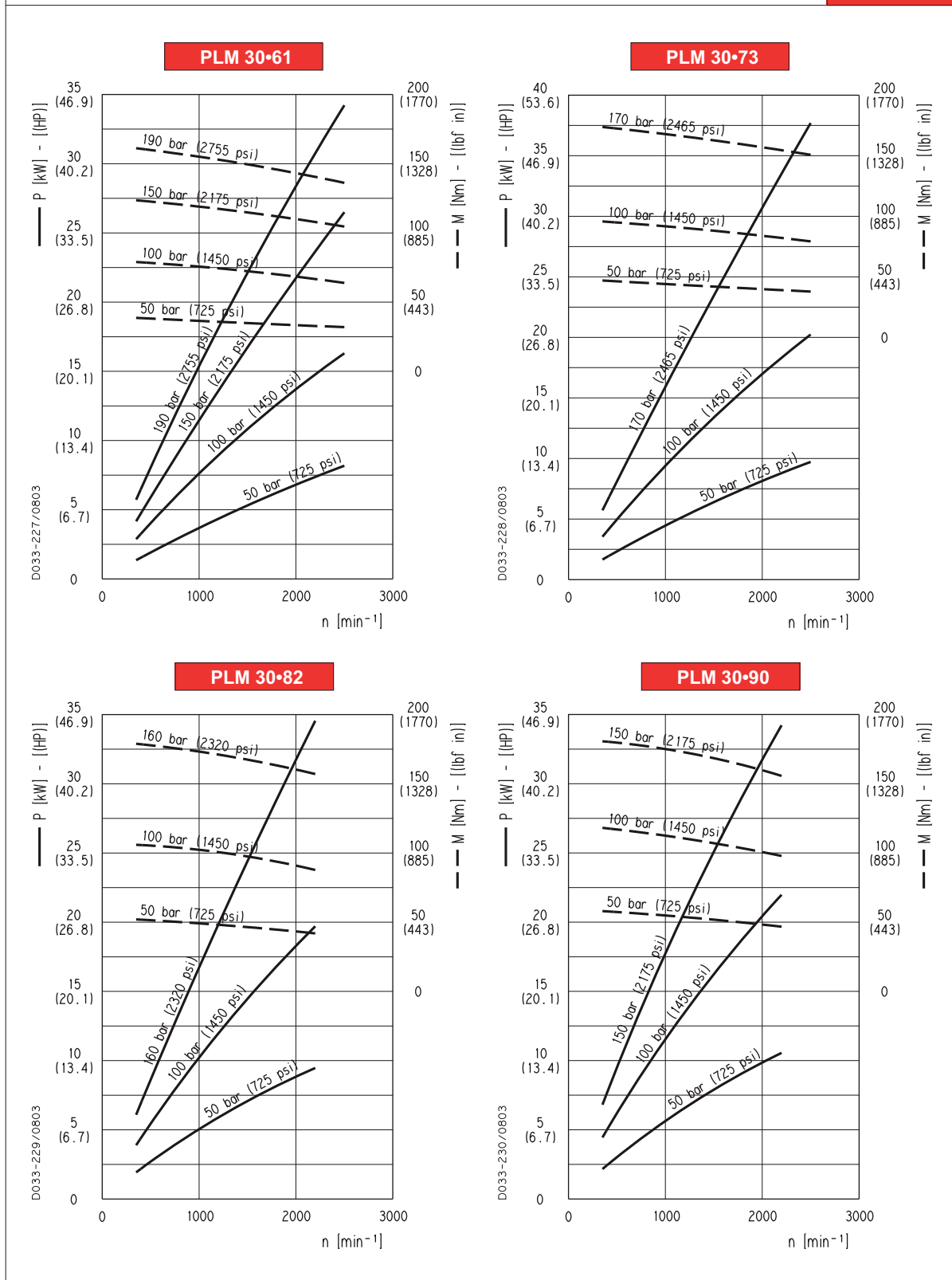

01/10.03