

Riduttore RT 190

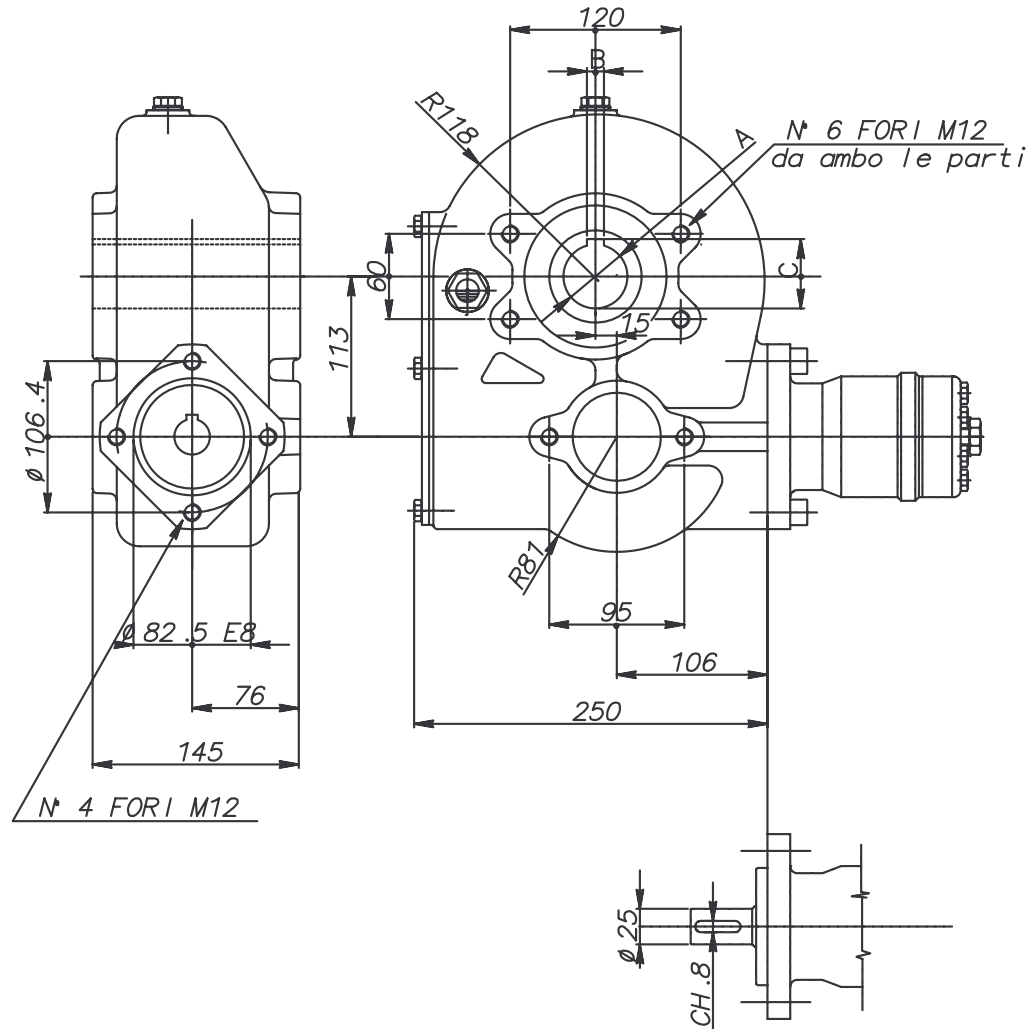

Marca	A E8	B E8	C	Peso kg.	Rapporto	Mt.in uscita N m	Olio Tipo	Quantita Kg	Temperatura d'impiego:
10323	35	10	38,8						
10324	40	12	43,8	28	10,2:1	1900	SAE 90 EP	2,5	-20° C +80° C
10325	45	12	48,8						

Bestell-Nr.	Code	Bezeichnung
520-010-01700	RT190/35	Kratzbodengetriebe-10323 10,2:1 1900Nm SAEA 25
520-010-01750	RT190/40	Kratzbodengetriebe-10324 10,2:1 1900Nm SAEA 25
520-010-01800	RT190/45	Kratzbodengetriebe-10325 10,2:1 1900Nm SAEA 25