

Riduttore RT 800

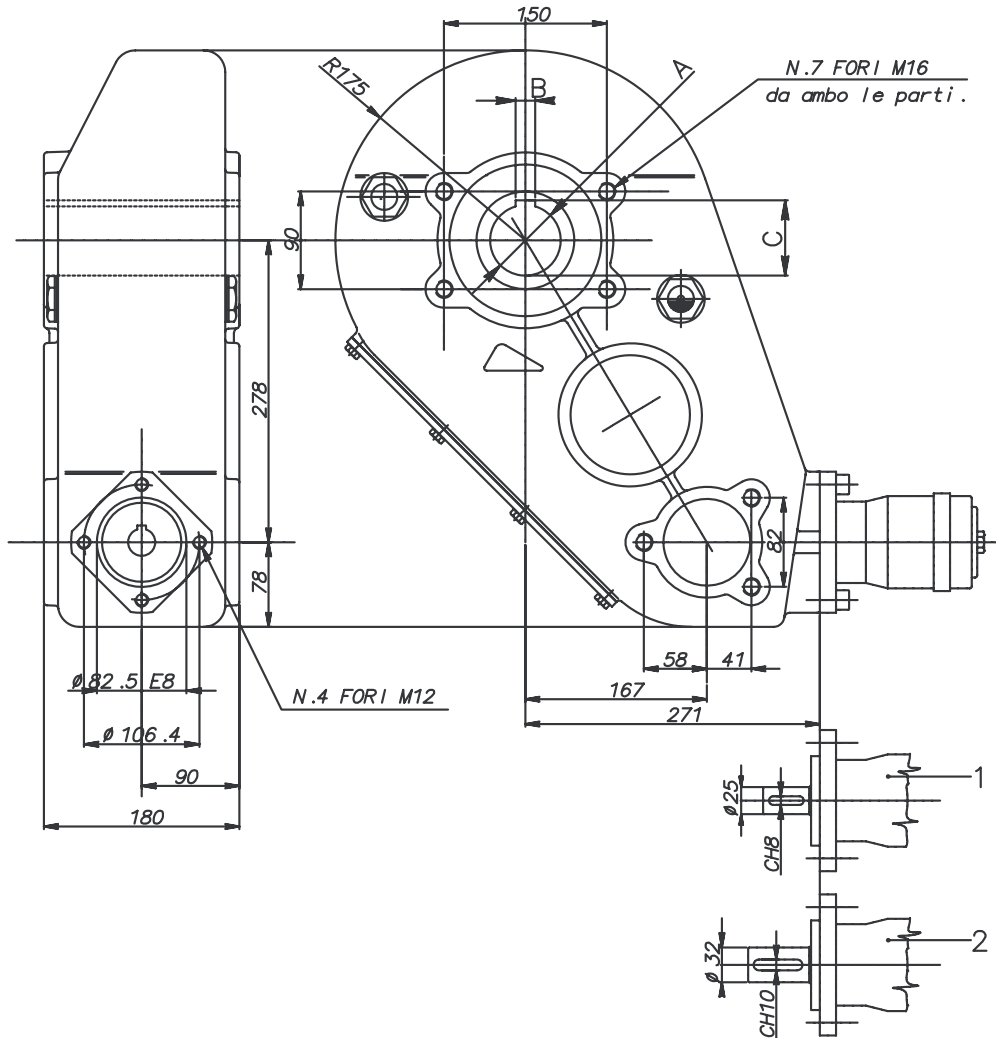

Marca	A E8	B E8	C	Attacco Motore	Peso kg.	Rapporto	Mt.in uscita N m	Olio Tipo	Quantita Kg	Temperatura d'impiego:
9479	55	16	59,3							
9470	60	18	64,4	1						
9480	65	18	69,4		88	31,7:1	8000	SAE 90 EP	9,5	-20° C +80° C
9481	55	16	59,3							
9482	60	18	64,4	2						
9483	65	18	69,4							

Bestell-Nr.	Code	Bezeichnung
520-010-02900	RT800/55	Kratzbodengetriebe-9481 31,7:1 8000Nm SAEA 32
520-010-02950	RT800/60	Kratzbodengetriebe-9482 31,7:1 8000Nm SAEA 32
520-010-03000	RT800/65	Kratzbodengetriebe-9483 31,7:1 8000Nm SAEA 32