

## Zahnradmotoren

- Serie XV -

Baugröße 2



Bestellnr.	Typ	Code
<b>D = rechtsdrehend</b>		
018-010-01000	XV2U/4D-BH-Ø50-C0.002	X2U4112FSRA
018-010-01100	XV2U/6D-BH-Ø50-C0.002	X2U4312FSRA
018-010-01200	XV2U/9D-BH-Ø50-C0.002	X2U4512FSRA
018-010-01300	XV2U/11D-BH-Ø50-C0.002	X2U4712FSRA
018-010-01400	XV2U/14D-BH-Ø50-C0.002	X2U4912FSRA
018-010-01500	XV2U/17D-BH-Ø50-C0.002	X2U5112FSRA
018-010-01600	XV2U/19D-BH-Ø50-C0.002	X2U5312FSRA
018-010-01700	XV2U/22D-BH-Ø50-C0.002	X2U5512FSRA
018-010-01800	XV2U/26D-BH-Ø50-C0.002	X2U5712FSRA
018-010-01900	XV2U/30D-BH-Ø50-C0.002	X2U5912FSSA
018-010-02000	XV2U/34D-BH-Ø50-C0.002	X2U6112FSSA
018-010-02100	XV2U/40D-BH-Ø50-C0.002	X2U6312FSSA
<b>S = linksdrehend</b>		
018-010-01050	XV2U/4S-BH-Ø50-C0.002	X2U4111FSRA
018-010-01150	XV2U/6S-BH-Ø50-C0.002	X2U4311FSRA
018-010-01250	XV2U/9S-BH-Ø50-C0.002	X2U4511FSRA
018-010-01350	XV2U/11S-BH-Ø50-C0.002	X2U4711FSRA
018-010-01450	XV2U/14S-BH-Ø50-C0.002	X2U4911FSRA
018-010-01550	XV2U/17S-BH-Ø50-C0.002	X2U5111FSRA
018-010-01650	XV2U/19S-BH-Ø50-C0.002	X2U5311FSRA
018-010-01750	XV2U/22S-BH-Ø50-C0.002	X2U5511FSRA
018-010-01850	XV2U/26S-BH-Ø50-C0.002	X2U5711FSRA
018-010-01950	XV2U/30S-BH-Ø50-C0.002	X2U5911FSSA
018-010-02050	XV2U/34S-BH-Ø50-C0.002	X2U6111FSSA
018-010-02150	XV2U/40S-BH-Ø50-C0.002	X2U6311FSSA

4-Loch-Flansch-BH-Durchschraubausführung -Bohrungsabstand = 60 x 60 mm / Rezz = Ø 50 mm / Welle -CO.002 1:5 -d = Ø 17,42 mm  
 -M 12x1,25 -Passfeder = 3,0 mm / max. zulässiges Wellendrehmoment = 233,2 Nm / Ölschlüsse = Flansch LK 35/40 seitlich

**In eine Richtung drehender Motor - Serie XV**

**XV-2U**

MOTOR TYP "BH"  
FLANSCH Ø50 GEFORMT - KEGELWELLE

**X 2 U 51 12 F S R A**

Serie	X	Serie XV
Gruppe	2	Gruppe 2
Kategorie	U	In eine Richtung drehender Motor
Hubraum	51	17
Flansch	12	Ø50 DEUTSCHE NORM BH Drehrichtung rechts
Welle	F	CO002 - Konisch 1:5 - Ø17.4 - M12x1.5 - Scheibenfeder Dicke 3
Gehäuse	IN	S Ansaugung - Ø40 a 45° Ø20 M6
	OUT	R Druckseite - Ø35 a 45° Ø15 M6
Deckel	A	Standard



XU210

Technische Datentabelle							
TYP	Hubraum	Maximaldruck		CODE			
		cm3/u	P1 bar	P3 bar	Drehung		
					links	rechts	
XV-2U/04	4,20	260	300	X 2 U 41 11 F S R A	X 2 U 41 12 F S R A	X 2 U 41 12 F S R A	
XV-2U/06	6,00	260	300	X 2 U 43 11 F S R A	X 2 U 43 12 F S R A	X 2 U 43 12 F S R A	
XV-2U/09	8,40	260	300	X 2 U 45 11 F S R A	X 2 U 45 12 F S R A	X 2 U 45 12 F S R A	
XV-2U/11	10,80	260	300	X 2 U 47 11 F S R A	X 2 U 47 12 F S R A	X 2 U 47 12 F S R A	
XV-2U/14	14,40	250	290	X 2 U 49 11 F S R A	X 2 U 49 12 F S R A	X 2 U 49 12 F S R A	
XV-2U/17	16,80	230	270	X 2 U 51 11 F S R A	X 2 U 51 12 F S R A	X 2 U 51 12 F S R A	
XV-2U/19	19,20	210	250	X 2 U 53 11 F S R A	X 2 U 53 12 F S R A	X 2 U 53 12 F S R A	
XV-2U/22	22,80	200	240	X 2 U 55 11 F S R A	X 2 U 55 12 F S R A	X 2 U 55 12 F S R A	
XV-2U/26	26,20	170	210	X 2 U 57 11 F S R A	X 2 U 57 12 F S R A	X 2 U 57 12 F S R A	
XV-2U/30	30,00	160	200	X 2 U 59 11 F S S A	X 2 U 59 12 F S S A	X 2 U 59 12 F S S A	
XV-2U/34	34,20	150	190	X 2 U 61 11 F S S A	X 2 U 61 12 F S S A	X 2 U 61 12 F S S A	
XV-2U/40	39,60	140	180	X 2 U 63 11 F S S A	X 2 U 63 12 F S S A	X 2 U 63 12 F S S A	

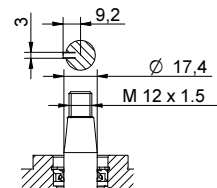
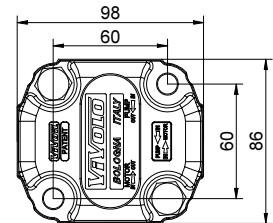

P1) Max. Betriebsdruck - P3) Max. Druckspitze  
Für schwere Anwendungen empfiehlt sich eine Prüfung des zulässigen Wellendrehmoments

Dimensionstabelle											
TYP	Gewicht	A	B	C	D	E	F	D	E	F	
		mm	mm	mm	mm	mm	mm	mm	IN		
									IN	OUT	OUT
XV-2U/04	2,100	87,2	38,6	77,2	Ø15	35	M6x1	Ø20	40	M6x1	
XV-2U/06	2,200	90,2	38,6	80,2	Ø15	35	M6x1	Ø20	40	M6x2	
XV-2U/09	2,300	94,2	40,6	84,2	Ø15	35	M6x1	Ø20	40	M6x3	
XV-2U/11	2,400	98,2	45,0	88,2	Ø15	35	M6x1	Ø20	40	M6x4	
XV-2U/14	2,600	104,2	45,0	94,2	Ø15	35	M6x1	Ø20	40	M6x5	
XV-2U/17	2,700	108,2	45,0	98,2	Ø15	35	M6x1	Ø20	40	M6x6	
XV-2U/19	2,800	112,2	45,0	102,2	Ø15	35	M6x1	Ø20	40	M6x7	
XV-2U/22	2,950	118,2	52,5	108,2	Ø15	35	M6x1	Ø20	40	M6x8	
XV-2U/26	3,050	122,2	52,5	112,2	Ø15	35	M6x1	Ø20	40	M6x9	
XV-2U/30	3,300	130,2	60,7	120,2	Ø20	40	M6x1	Ø20	40	M6x10	
XV-2U/34	3,500	137,2	60,7	127,2	Ø20	40	M6x1	Ø20	40	M6x11	
XV-2U/40	3,700	146,2	60,7	136,2	Ø20	40	M6x1	Ø20	40	M6x12	

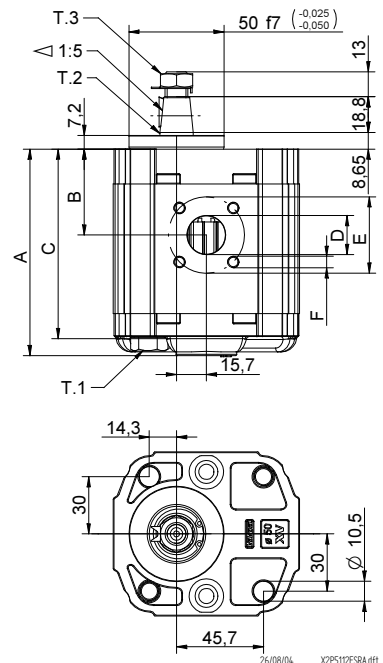

T.1 = 54+58.9 [Nm] - Anzugsmoment - Schrauben M10  
T.2 = 233.2 [Nm] - zulässiges Wellendrehmoment (N.B. Zur Auswahl der Welle stets das zulässige Drehmoment prüfen).  
T.3 = 40 [Nm] - Anzugsmoment - Schlüssel 19

## Tabelle der Varianten

XV-2U

FLANSCH  $\varnothing 50$  "BH" – Geformt

FLANSCH $\varnothing 50$ "BH" – Geformt				Welle				Deckel					
Drehung links		Drehung rechts						Drehung links		Drehung rechts			
	11		12	CI001 - Zylindrisch T.2 = 44.1 [Nm]	A	CI002 - Zylindrisch T.2 = 67.5 [Nm]	B				A		
	13		14	CO001 - Konisch T.2 = 233.2 [Nm]	E	CO002 - Konisch T.2 = 233.2 [Nm]	F				B		
	15		16	SCF03 - genutet T.2 = 86.1 [Nm]	H						C		
	17		18								D		

Hubraum	
TYP	CODE
XV-2U/04	41
XV-2U/06	43
XV-2U/09	45
XV-2U/11	47
XV-2U/14	49
XV-2U/17	51
XV-2U/19	53
XV-2U/22	55
XV-2U/26	57
XV-2U/30	59
XV-2U/34	61
XV-2U/40	63

Gehäuse Standard						
Hubraum	cm <sup>3</sup> /u	Standardgewinde				
4	O - O	S - R	B - B	L - M	Z - Z	
6	O - O	S - R	B - B	L - M	Z - Z	
9	O - O	S - R	B - B	L - M	Z - Z	
11	O - O	S - R	B - B	L - M	Z - Z	
14	P - O	S - R	C - B	L - M	Z - Z	
17	P - O	S - R	C - B	L - M	Z - Z	
19	P - O	S - R	C - B	L - M	Z - Z	
22	P - O	S - R	C - B	L - M	Z - Z	
26	Q - P	S - R	D - C	L - M	Z - Z	
30	Q - P	S - S	D - C	L - M	Z - Z	
34	Q - P	S - S	D - C	L - M	Z - Z	
40	Q - P	S - S	D - C	L - M	Z - Z	

Kombinationstabelle der lagermäßig vorrätigen  
Standardgewinde und Anflansungen

		N
Drainage innen		
		O
Drainage aussen		

Gehäuse (Gewinde und Anflansungen)													
	A		B		C		D		E		F		G
	H		I		L		M		N		O		P
	Q		R		S		T		U		V		Z