

RS 14-1

RS 14-1

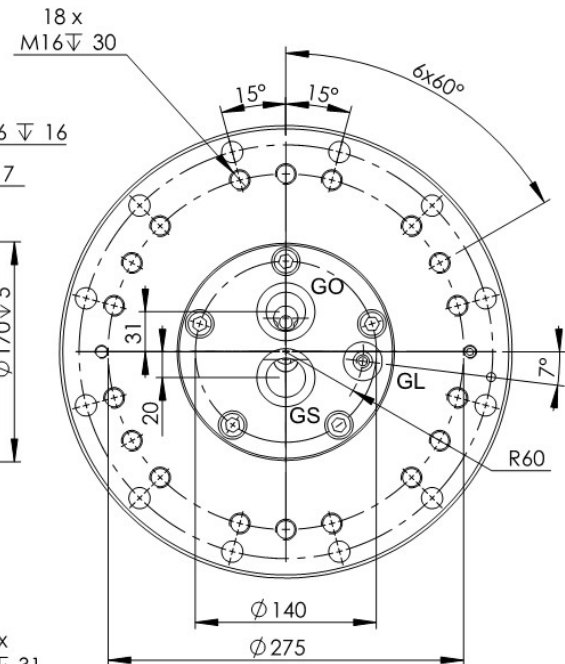
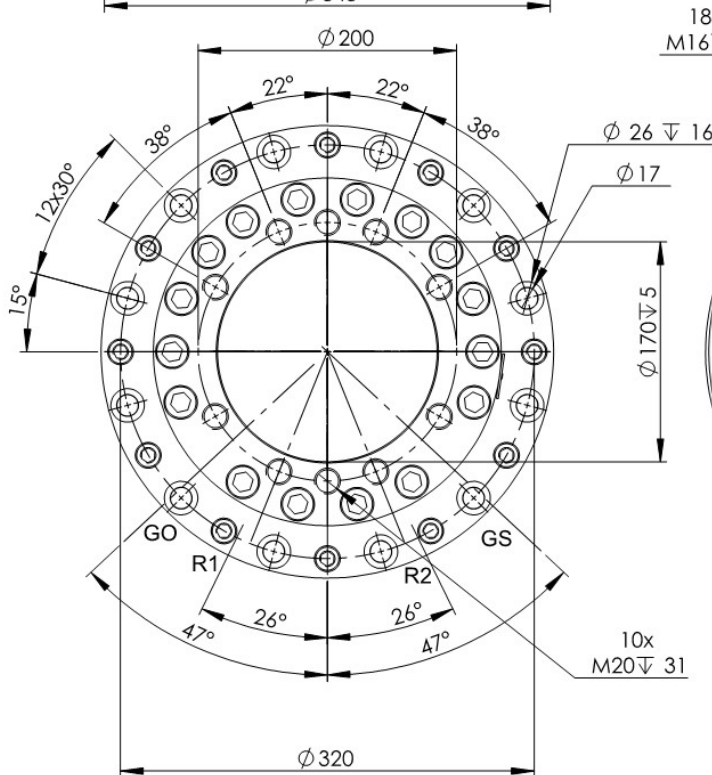
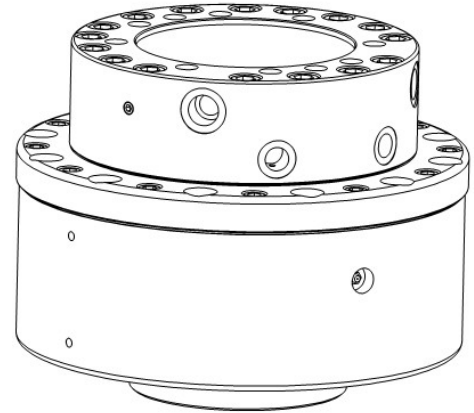
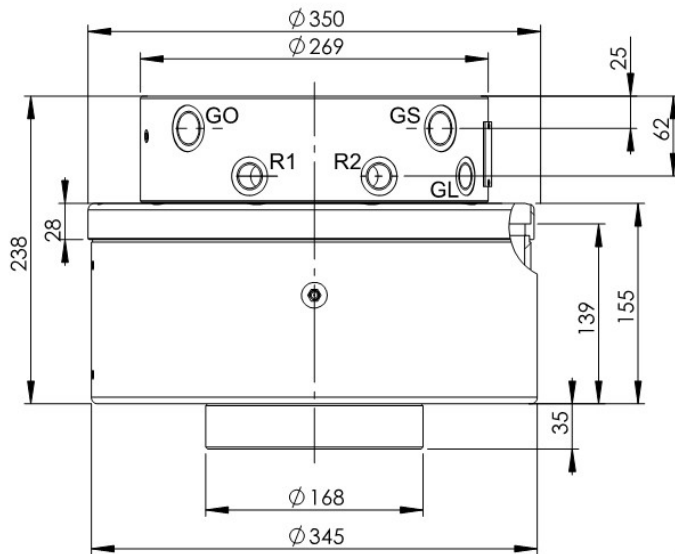

Technische Daten / technical data

Traglast axial	load axial:	(kg)	14000
Drehmoment	torque:	(Nm)	3800
Drehzahl	rotational speed:	(U/min.)	18
Betriebsdruck	operating pressure		
Drehen max	rotating max:	(bar)	320
Greifer max	rotary feedthrough max:	(bar)	350
Gewicht	weight:	(kg)	118

erforderlicher Ölfluss beim Drehen / recommended flow

minimum:	(l/min)	15
optimal:	(l/min)	25

Anschlüsse / connections

R1 (1/2")	Drehen links / rotation left
R2 (1/2")	Drehen rechts / rotation right
GO (3/4")	Greifer öffnen / clamshell open
GS (3/4")	Greifer schließen / clamshell close
GL (1/2")	Lekage / leakage
Einsatzgebiet Baggerdielengewicht / operating fields (t)	
Kardanisch / cardanic suspension:	28
Materialumschlag / materialhandling:	28
Festanschluss / fix connection:	14

Technische Änderungen vorbehalten / technical changes reserved

Blatt / sheet:
1 von 1

Ausgabe / version:
A

Datum / date:
30.01.2011

Datenblatt / data sheet